

The Ribbon Sink

TSL.NANO.R

installation + maintenance

+
THE
SPLASH
LAB

contents

3	The Ribbon Sink
4	Components List
5	Technical Data
6-7	Before you Install
8-10	Installation
11	Operation & Maintenance
12	Cleaning & Repairs
13	Damage Prevention
14	Warranty

The Ribbon Sink

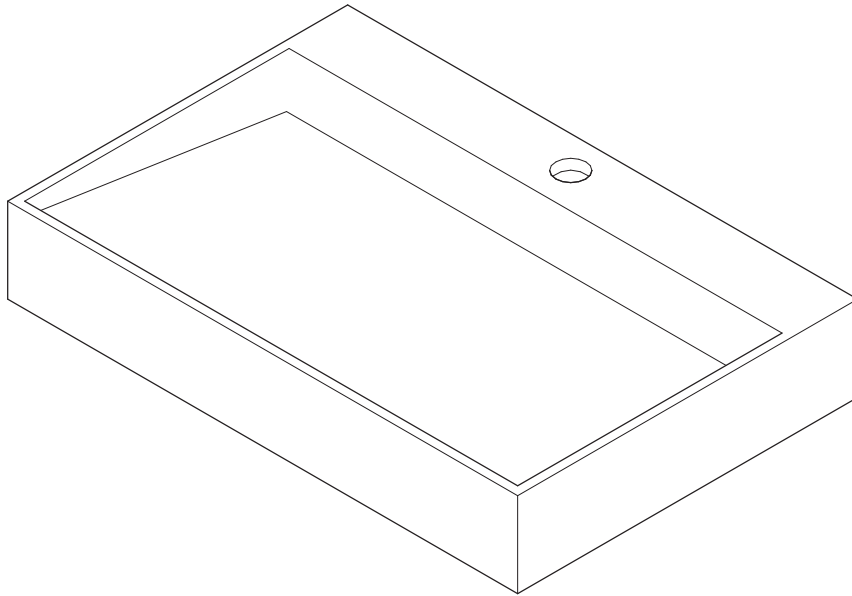

The Ribbon Sink

The Splash Lab Ribbon Sink is a small and compact single-user basin, constructed from solid surface material, well suited to any washroom.

The Ribbon Sink

components list

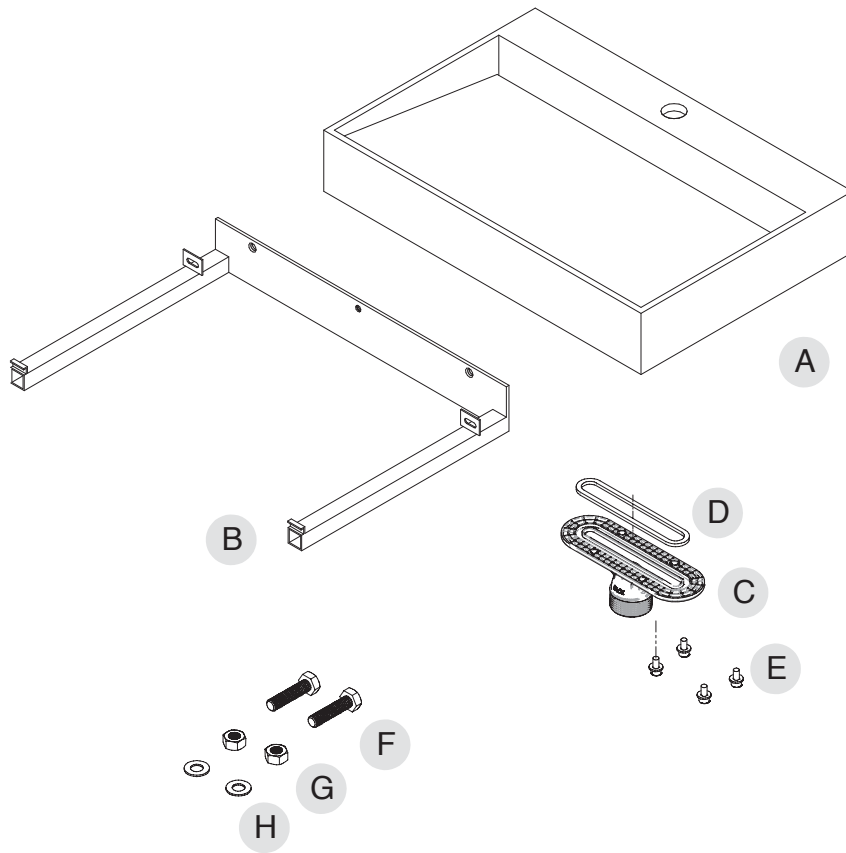

		30"
A	Trough	1
B	Mounting bracket	1
C	Drainage funnel	1
D	Drainage funnel gasket	1
E	Drainage funnel hardware (M6 x 12 screw and washer)	4
F	Mounting bolts (M6 x 35)	2
G	Fixing nuts	2
H	Washers (M6)	4

Please check that all components are included and contact The Splash Lab if any parts are missing. Wall attachment hardware is not included for fastening the brackets to the wall as the requirements of each location is different. The Splash Lab recommends that you consult a licensed contractor for the most appropriate method for your project.

The Ribbon Sink

technical data

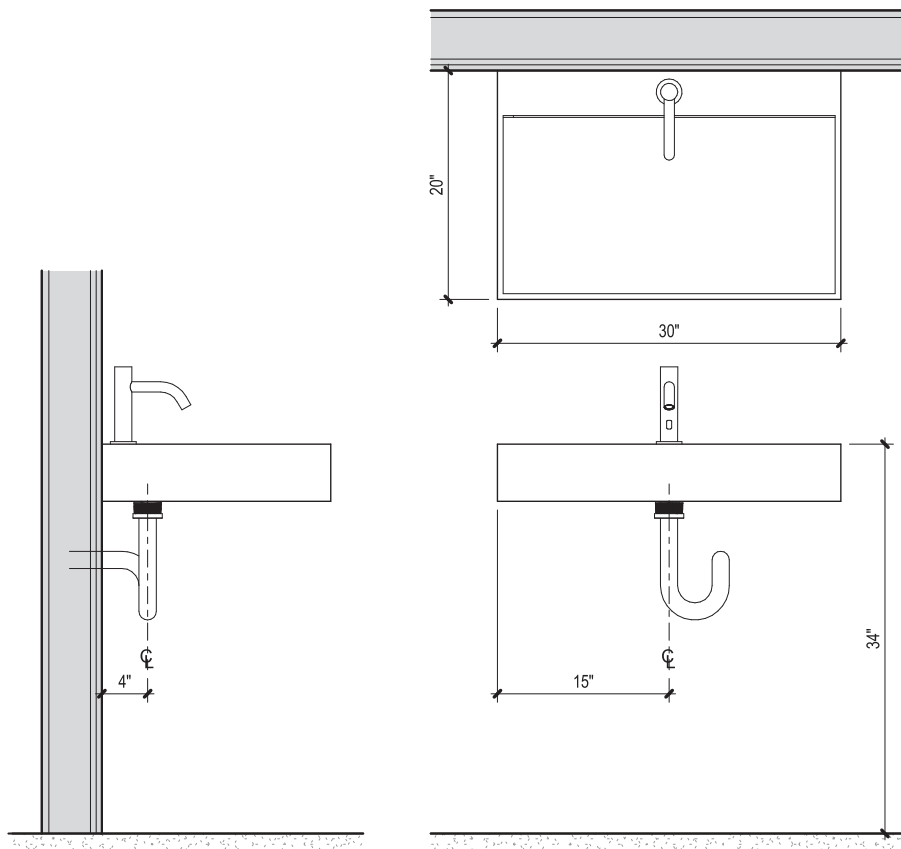

	30"
Material	Solid Surface
Weight (lb)	40.5
Overall Dimensions (in)	30" x 20" x 5"
Waste Connections	1

P-Trap to be installed by licensed plumber.

The Ribbon Sink

before you install

1. Metal or wood studs need to be capable of supporting the weight of the sink. See the table on page 18 for stud spacing. Allow a space of at least 3 1/2" - 4" behind the wall for easy access to plumbing connections. It is also recommended that access panels are created as part of the wall construction to allow for initial installation and maintenance of the plumbing. Depending on the individual installation, the access panel could either be above or below The Ribbon Sink.

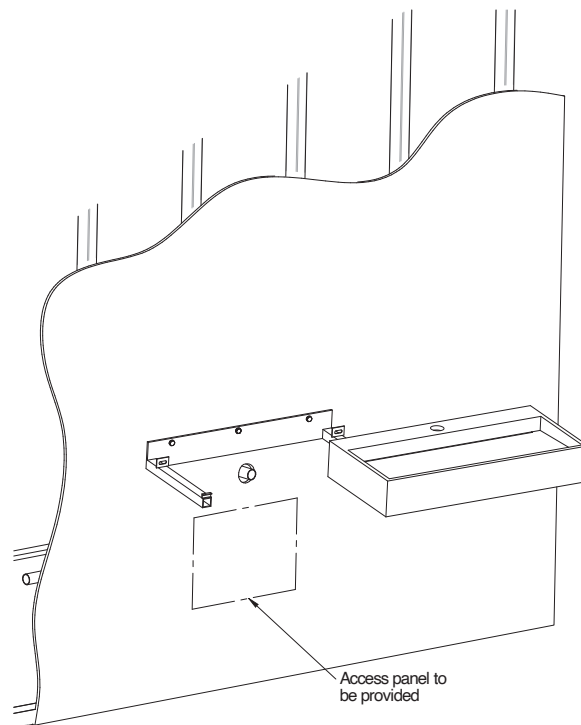

2. A water supply is required to operate the faucet.
3. A waste water connection and appropriate trap is required to connect to the 1 1/4" NPT thread on the waste funnel. The trap should conform to the current waste water regulations.
4. For Ribbon Sinks with wall-mounted faucets, the water supply pipes should be within the wall space (usually an IPS panelling system) to allow for connection to wall-mounted faucets.
5. For Ribbon Sinks with deck-mounted faucets the water supply should be routed underneath the sink to allow for connection to deck-mounted faucets.

The Ribbon Sink

before you install

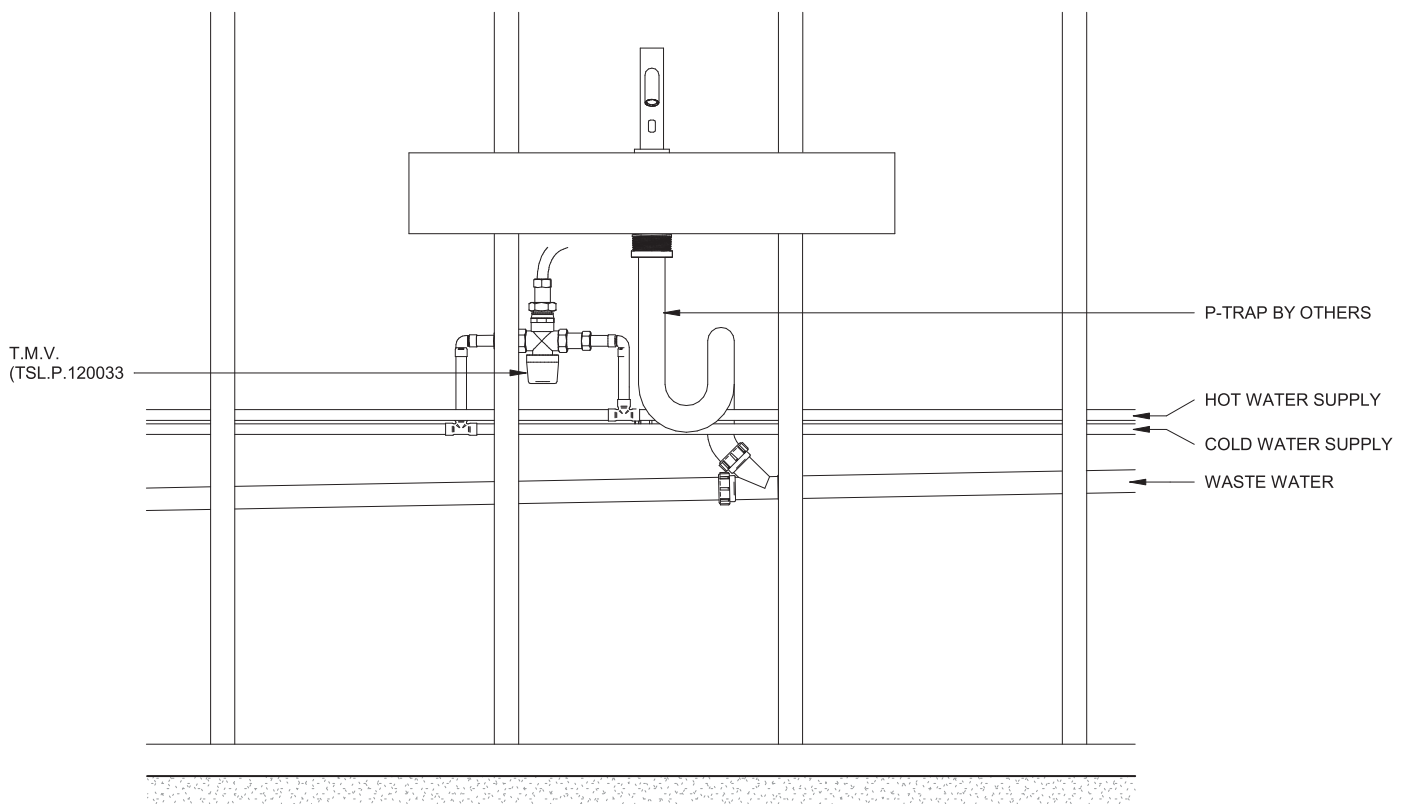

The Ribbon Sink installation

1

Mark the bracket attachment points on the wall.

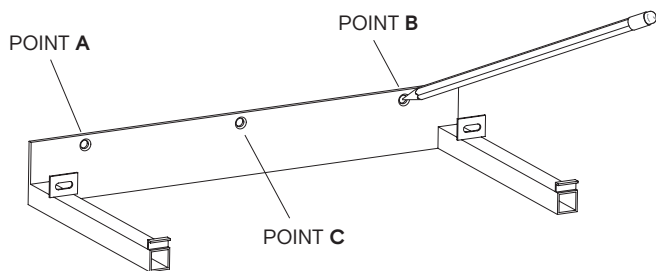

2

Drill where marked for attachment.

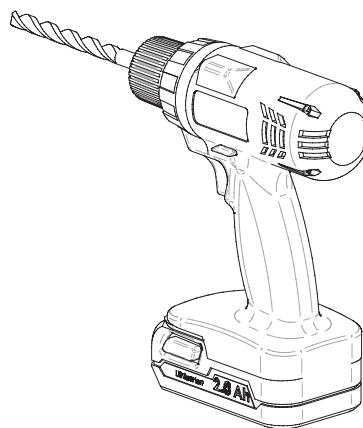

3

Attach the bracket through point A first and then, with sink level through point B

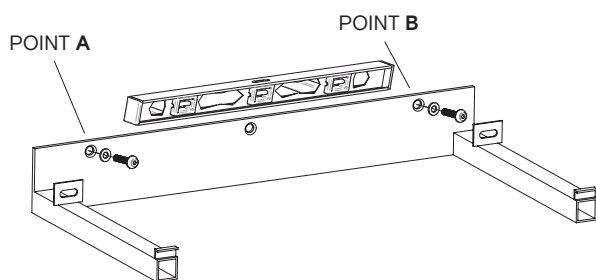

4

Ensure the bracket is level along its length so that the water properly drains out of the trough.

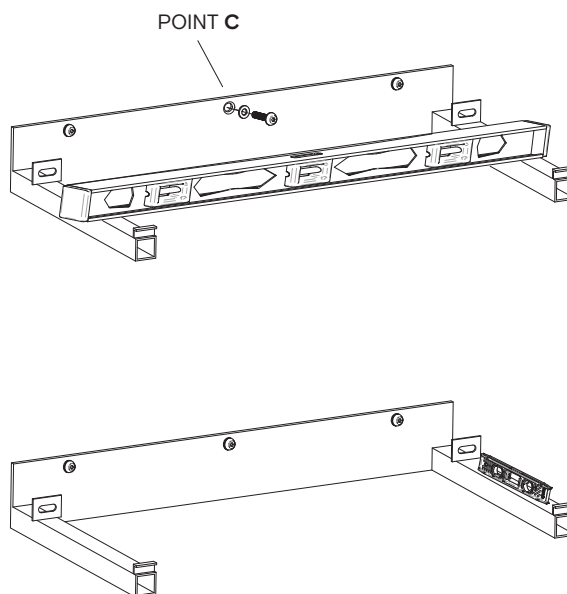

5

Finally lock bracket in place through point C.

The Ribbon Sink installation

6

With the Ribbon Sink placed face-down, fit the waste funnel to the funnel adapter plate on the underside of the basin.

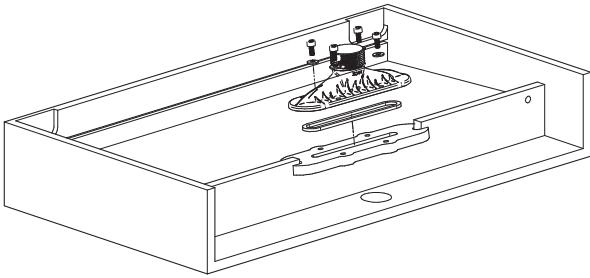

7

Place the Ribbon Sink over the front of the mounting tabs onto the wall brackets.

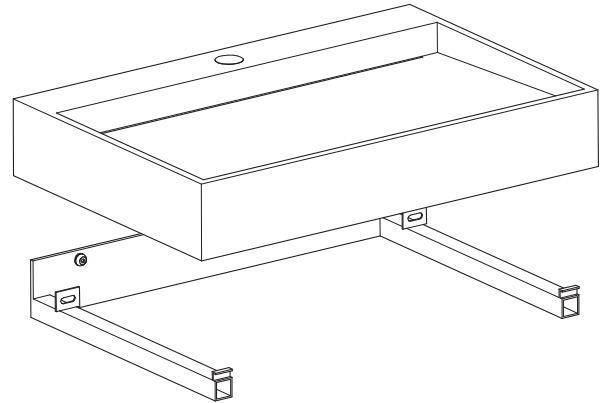

Ensure that the sealing gasket is correctly fitted into the recess on the funnel and tighten the 4 bolts.

8

When rear of the Ribbon Sink is resting on brackets, slide towards the wall until the tabs are sitting against the front mounting rail on the Ribbon Sink. The front tab on the bracket must locate into the corresponding groove on the front mounting rail on the Ribbon Sink.

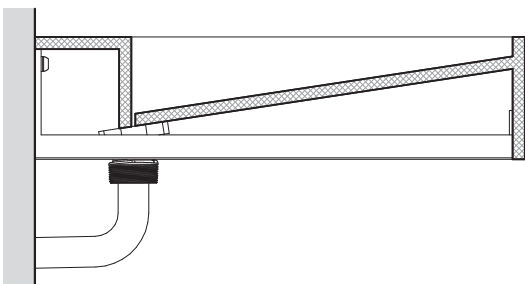

9

Once the Ribbon Sink is in place, mount it to the wall brackets through the mounting rail using the M6 x 40 screws and nuts provided.

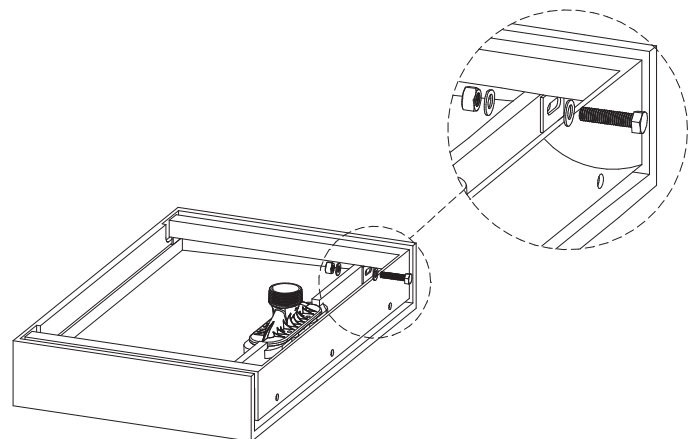

The Ribbon Sink

installation

10

Plumber to fit P-Trap to drain funnel and connect to waste pipe previously installed.

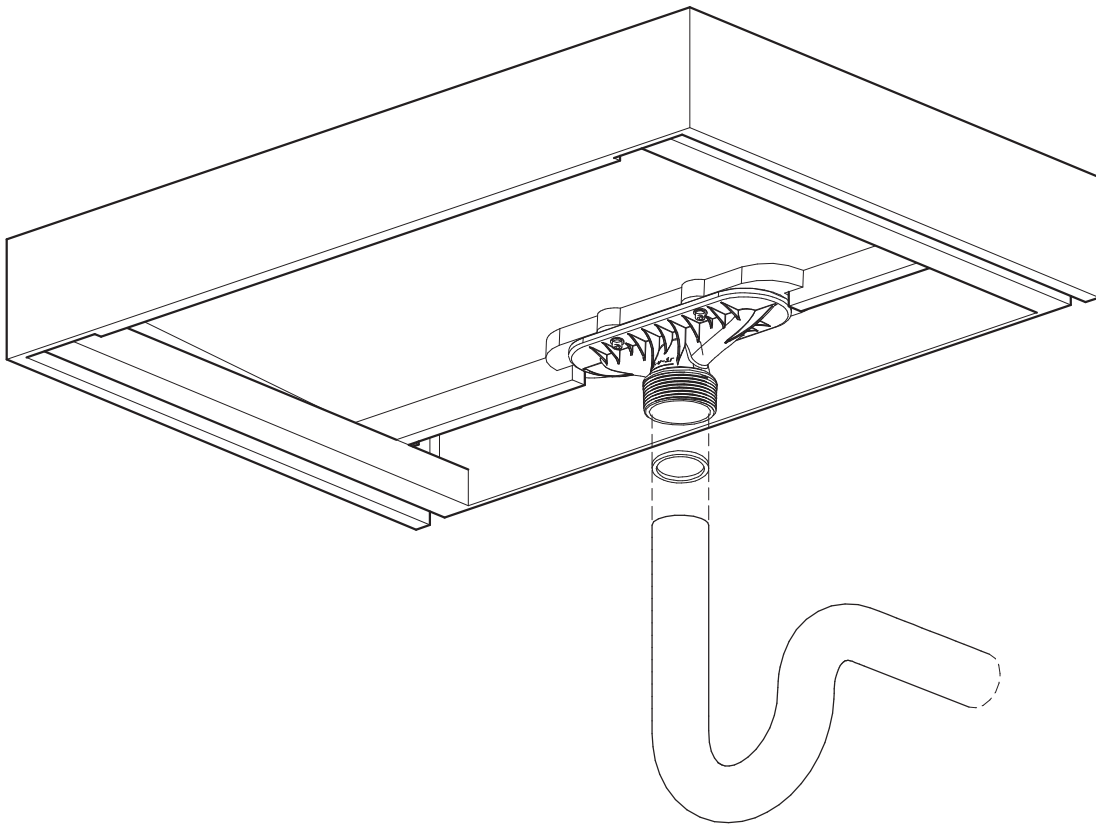

operation

The user will activate an automatic sensor faucet or a manual faucet, allowing the water to flow and wash their hands in the normal manner.

maintenance

The Ribbon Sink should be periodically inspected for any damage. The Ribbon Sink should be tested to ensure that the water drains out of the basin, and that the drainage waterways are not blocked with any debris.

cleaning

The Splash Lab Ribbon sinks are finished in a matte / satin finish, unless otherwise specified. The surface can be cleaned with a mild solution of soapy water, ammonia-based cleaners or most commercially available solid-surface cleaners. These will remove most dirt and other residue from the surface.

Cleaning Techniques

- + Washing with soap and water is usually sufficient to remove surface dirt or stains.
- + Ammonia based liquid cleaner (not window cleaner) can also be used. Always rinse surface thoroughly and wipe dry.
- + Drying is an important step, preventing a build-up of soap film or cleaning residue, which can create the appearance of light scratches over time.
- + Stubborn soap film or cleaning residue build-up on solid surfaces are easily removed with abrasive cleaners and a white abrasive pad or sponge.
- + For darker colors, a polish may be used to enhance the shine. For areas where there is the possibility of contact with food, a polish formulated for use in food-contact areas must be used. Where food contact is not likely to occur, a simple furniture polish can be used. Always follow the manufacturer's instructions for using the polish and for safety concerns.

Cleaning Agents

The Splash Lab solid surface is unaffected by common household and commercial cleaners such as:

- + Powdered abrasive cleaners
- + Ammonia
- + Strong detergents
- + Oxalic acid solutions
- + Dilute hydrochloric acid solutions
- + Dilute trisodium phosphate solutions

Acid drain cleaners may cause damage

repairs

Severe scratches can be removed using 180G abrasive paper in a circular motion on the affected area. Most other damage or chips to The Splash Lab Solid Surface material can be repaired with no visible evidence.

Please contact The Splash Lab technical department for damage evaluation and repairs.

damage prevention

Some chemicals are not compatible with The Splash Lab solid surface. Contact should be avoided with the following chemicals:

- + Strong chlorinated solvents
- + Chloroform
- + Ketones
- + Methylene chloride (paint removers)
- + Very strong acids such as concentrated sulphuric and hydrochloric acids
- + Acid drain cleaners should not be used.

Surfaces exposed to these agents should be promptly ushed with water. Contact for even a short period of time can cause surface damage, spots, or staining. Follow the recommended repair procedures described above as needed to repair and/or restore the surface to its original condition. Severe damage caused by incompatible chemical contact will require professional repair. Contact The Splash Lab technical department for assistance.

faucets

See separate maintenance guide for maintenance of sensor faucets (where applicable).

soap dispensers

See separate maintenance guide for maintenance of soap dispensers (where applicable).

If further information is required, contact The Splash Lab technical team.

warranty

The Splash Lab will replace necessary parts, free of charge, if they are defective from the manufacturer. The Splash Lab guarantees all of its products against manufacturing defects under the terms and conditions listed below

Sinks **TSL backs every sink with a lifetime guarantee against material defect.**

Not Covered

- Components subject to wear and tear.
- Items or parts that are damaged or not working properly due to misuse, negligence or improper maintenance.
- Improper installation or installation by a non-licensed technician.
- Failure from external causes such as physical damage; exposure to adverse or hazardous chemicals or other substances; use of reactive cleaning agents and/or harsh chemicals, or acts of nature.
- Stains on natural finishes, such as brass or stainless steel, that have been exposed to the natural environment or improperly maintained.
- Parts that have been modified.
- Moving parts installed in high-traffic areas. The Splash Lab offers customized warranty options for high-traffic areas; please contact TSL for details.
- Installation of replacement parts or labor costs.

Installation Requirements

This product must be installed by licensed technicians following the steps in the instruction guide provided. Altering or modifying any components of any product will void the manufacturer's warranty. If the recommended pressure and temperature are exceeded or reduced, the warranty is voided.

Maintenance Requirements

Never use abrasive sponges or products with abrasive substances such as chloride acid, ammonia, acetone, vinegar or, bleach. The usage of these products can cause permanent damage and will void the manufacturer's warranty.

If You Have a Claim

Defective products must be sent, shipping prepaid, to The Splash Lab with a copy of this warranty document and the purchase invoice included. Replacement products will be sent, shipping prepaid, to the address provided. If the cost of the replacement parts exceeds the purchase price of the product(s) the Splash Lab will reimburse the cost of the original items.

contact



General information

info.usa@thesplashlab.com
310 410 5008
20809 Higgins Ct
Torrance, CA 90501

Technical support

info.usa@thesplashlab.com

For further information visit:

www.thesplashlab.com/usa