

TSL.C.040

channel soap dispenser

installation + maintenance

+
THE
SPLASH
LAB

contents

3	Safety and Warnings
4	Box Contents
5	Technical Data
6	Before You Install
8	How to Install
13	Operation
13	Maintenance
14	Cleaning
15	Troubleshooting
16	Diagram
17	Warranty
Back Cover	Contact Details

TSL.C.040 channel soap dispenser

Read and save these instructions

WARNING 

To reduce the risk of fire, electric shock or injury to persons, observe the following:

- + Use this unit only in the manner intended by the manufacturer. If you have any questions, contact the manufacturer.
- + This equipment should be installed in a way that ensures all electrical parts are kept dry.
- + A means of electrical isolation must be incorporated in the fixed wiring, in accordance with the current local regulations in force.
- + Disconnect the power supply before performing any maintenance on the product.
- + Children should not play with this equipment. Cleaning and maintenance shall not be performed by children without supervision.
- + This equipment is designed to be used in commercial and public areas; it is not intended for domestic or residential use.
- + Ensure wiring and cover is installed correctly before connecting to live power supply.
- + If in doubt, consult an electrician.

General information

(310) 410-5008

Showroom:

8745 Washington Boulevard, Studio D, Culver City CA 90232

Warehouse + Offices:

20809 Higgins Court, Torrance CA 90501

Technical support

info.usa@thesplashlab.com

For further contact information visit:

www.thesplashlab.com/usa

box contents

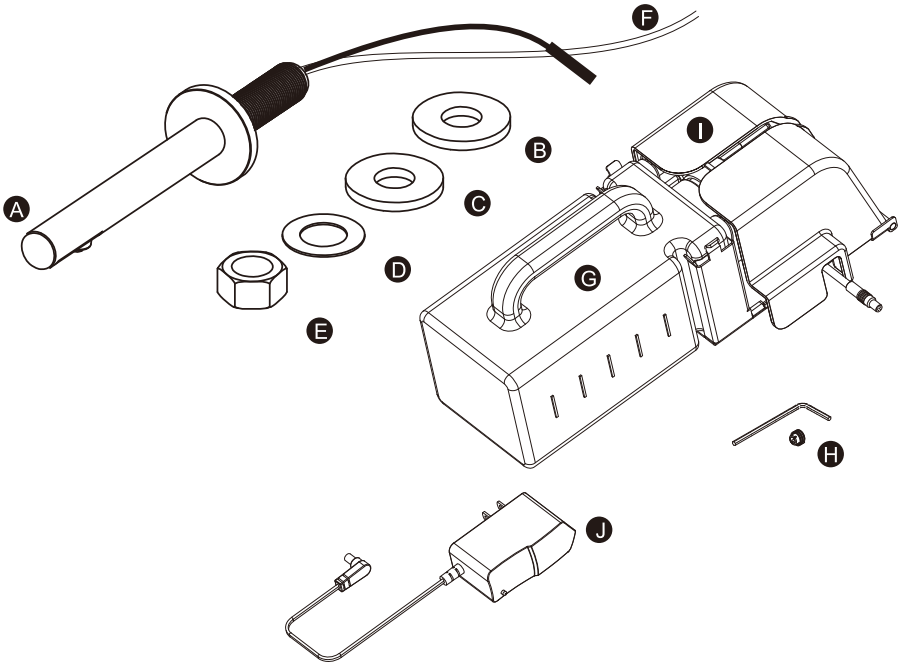

A	Dispenser head assembly
B	Pad (already installed)
C	Gasket
D	Washer
E	Fixing nut
F	Soap foaming pipe
G	Soap reservoir - 0.4 gallons
H	Hex wrench/ Soap outlet
I	Soap foamer pump unit
J	Power supply unit

technical data

Finishes	TSL.C.040.C	Bright Polished
	TSL.C.040.CS	Brushed Stainless
	TSL.C.040.CP	Brushed Copper
	TSL.C.040.BK	Brushed Black
	TSL.C.040.BR	Brushed Brass
<hr/>		
Power supply - Mains	Input 100-240V ac; 50/60Hz Output 6V DC, 1.5A, 9W max	
<hr/>		
Power supply - Battery	6V Type AA x 4 pcs Alkaline (not included)	
<hr/>		
Standby power	9mA	
<hr/>		
Weight	2lb 3oz	
<hr/>		
Material	316 stainless steel	
<hr/>		
Sensor range	2 3/4" ±19/32"	
<hr/>		
Recommended soap viscosity	Foam soap: - <10cPs	
<hr/>		
Approvals	CE, RoHS, ADA	
<hr/>		
Warranty	One year limited warranty	
<hr/>		

before you install

Power supply

An Outlet must be provided for connection to the mains power supply.

Basins

The Splash Lab Monolith (Series C or D) basin is recommended for use with the Channel range of products. If an alternative basin is used, please confirm with The Splash Lab that there will be no reflection or splash issue.

Spacing

If the Channel Soap Dispenser is installed with the Channel Faucet, it should be 6" to the left of the Faucet, which is at the center. The Channel Dryer should be 8" to the right of the Faucet.

Backplate

The Splash Lab offers an optional backplate for the fixtures that allows the fixtures to be mounted from the front and have simpler access.

Front view

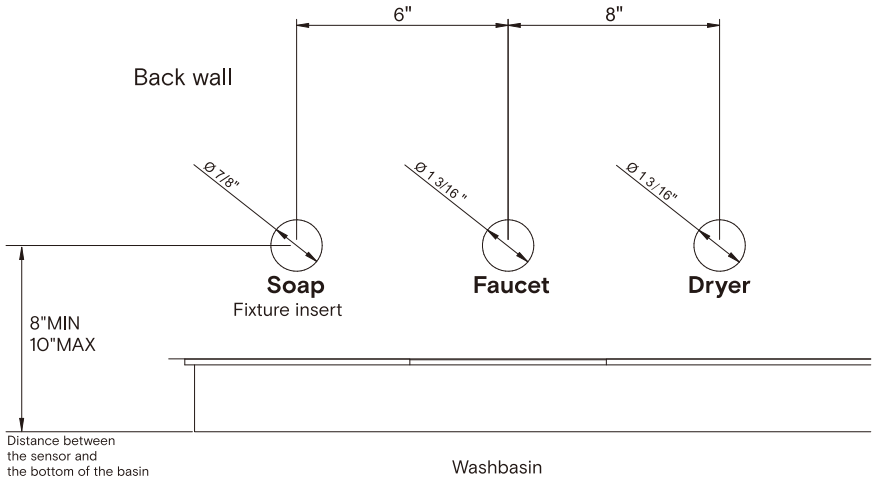

before you install

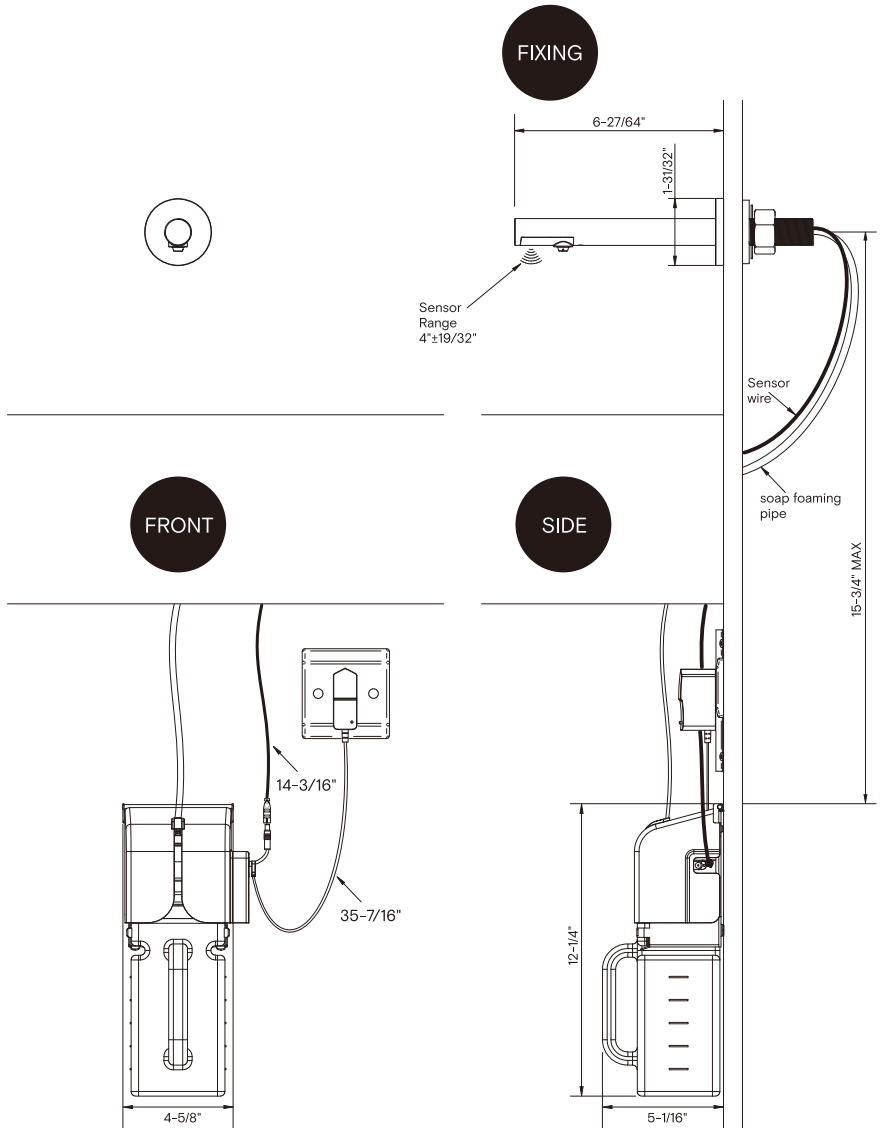

how to install

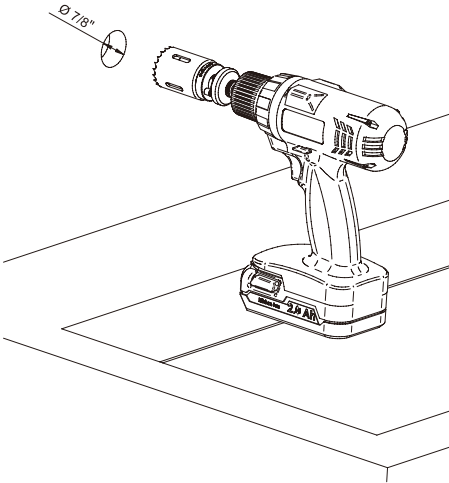

1

Drill hole 7/8" diameter in wall 8-10" above the bottom of the basin.

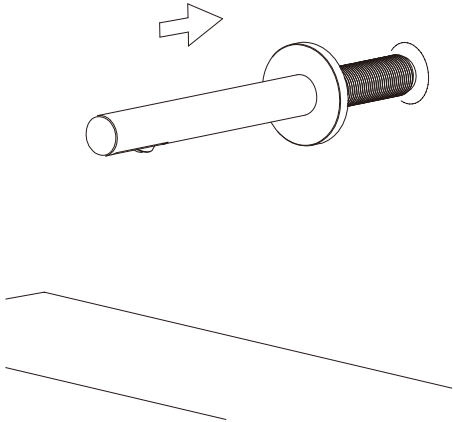

2

Fit dispenser body into the 7/8" hole in wall.

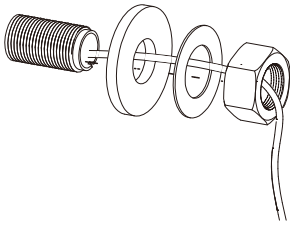

3

The sensor wire and soap foaming pipe go through the gasket, washer and fixing nut. Tighten the nut against the installation wall.

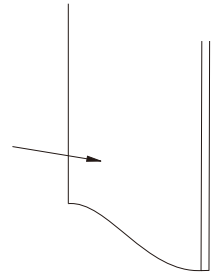
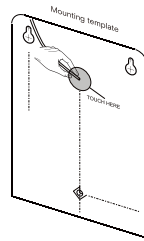
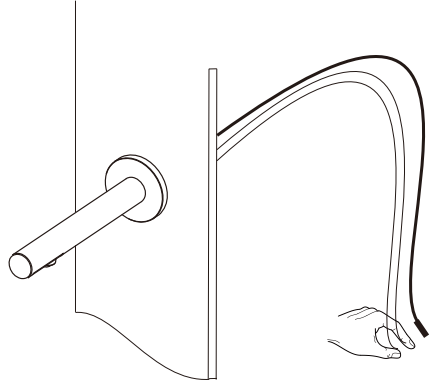

4

Place Mounting template on the wall to find the best position for installing.

how to install

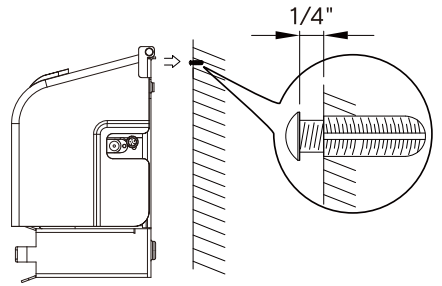
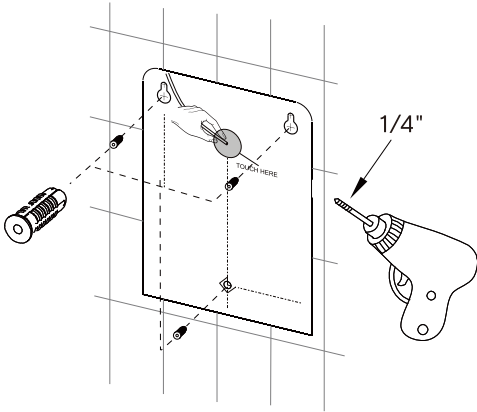

5

Put the mounting template in the best installation position on the wall according to the position of the holes in the mounting template. Then drill 3 holes (size:1/4") and put the 3 wall plugs, included in kit, in the holes. Contractor may use other size.

6

Screw two screws into the top wall plugs, but leave a 1/4" space between the head of the screw and wall, so the control box assembly can hang properly.

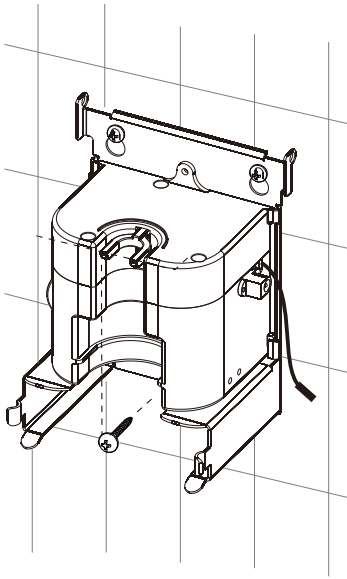

7

When the control box assembly has been hung on the wall, fasten the third screw into the bottom wall plug.

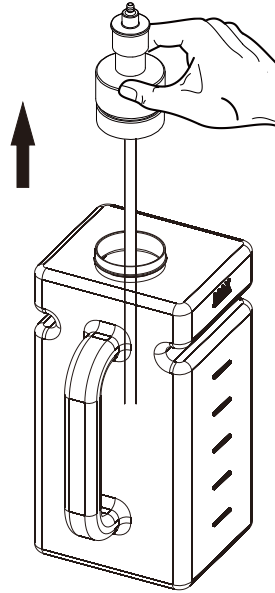

8

Pull up the soap pump, fill in the liquid soap and then push down the soap pump until you hear it snap into place.

how to install

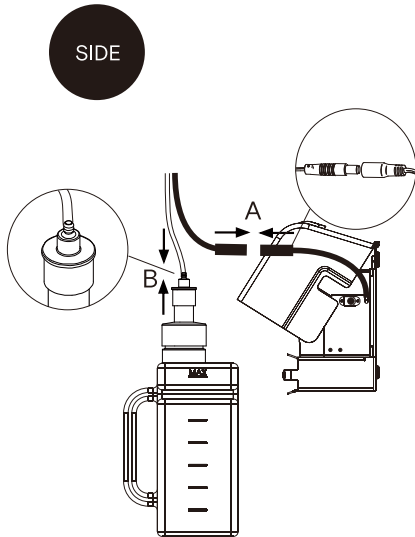

9

Connect the wire of the soap dispenser to the wire of the control box assembly. Connect the tube of the soap dispenser to the connector on the soap pump. The overall length of the soap tube is 39-3/8". For a suitable length for installation, cut the tube as short as possible to save battery life and to improve soap volume.

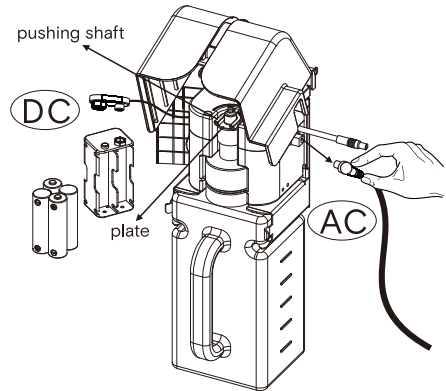

10

Push the soap tank to the track. Make sure the soap pump plate is under the pushing shaft before you put back the soap tank, so the soap dispenser can work properly. Plug-in an AC adapter or battery box to supply power. Installation finished.

*To use power mains as the power source, do not place batteries in the battery compartment.

To use batteries as the power source, insert the batteries in the battery compartment and disconnect the barrel connector of the AC adapter from the control box. The life cycle of the soap dispenser based on using batteries as the power source is about 15,000 cycles.

operation

- + The user is to place hands under the sensor to activate the dispenser.
The user then places hands within the detection range of the sensor to activate the soap dispenser.
- + The motor will start and soap is dispensed onto the user's hands.

maintenance

- + The soap dispenser should be serviced on a regular basis to ensure long service life of the unit.
- + Isolate the unit from the power supply before any servicing or maintenance work is carried out.
- + The dispenser should be activated at least once a day to ensure that soap does not congeal in the pipework.

cleaning

- + All grades of stainless steel will stain or discolor if due care and attention is not taken. The surface must be regularly cleaned to ensure a long service life of the soap dispenser.
- + Use a soft cloth or sponge with a mild solution of soapy water as part of the regular washroom janitorial routine. Do not use abrasive or cream cleaners as these will damage the surface finish.
- + If the soap dispenser is subjected to a highly chlorinated environment e.g. swimming pools or marine coastal locations, a further treatment, in addition to the regular cleaning as described above, is recommended to use a household cleaning product containing silicone.
- + If further information is required, contact The Splash Lab Team for more detailed stainless steel care guidelines.

troubleshooting

If the dispenser will not run

- + Ensure there is power to the dispenser and the wire from the AC adapter is connected correctly to the pump motor.
 - + Check that the sensor cables are fully connected to the corresponding cables from the foam pump unit.
 - + If you use DC type, replace the battery with a new one if the battery is low.
-

If the dispenser can be heard to operate, but soap is not dispensed

- + Check that the soap pick-up pipe is fully immersed in the soap in the reservoir. If necessary, replenish the soap in the reservoir.
 - + Check that there are no leaks in the pipework, and that all connections are fully pushed home.
-

If the dispenser runs all the time

- + It is likely that the sensor is detecting either an object, or reflection causing it to operate constantly.
 - + Remove the obstruction or cause of reflection.
-

We are always looking to improve. If these steps did not solve your problem please contact us and we will endeavor to help.

Tel: (310) 410-5008

Email: info.usa@thesplashlab.com

diagram

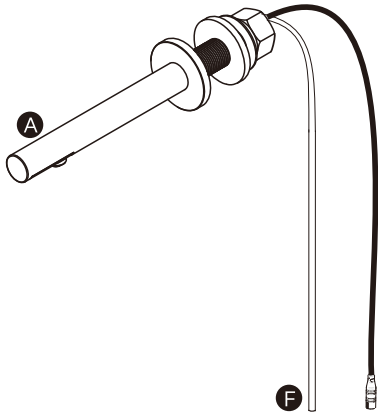

- A Dispenser head assembly
- F Soap foaming pipe
- G Soap reservoir - 0.4 gallons
- I Soap foamer pump unit
- J Power supply unit

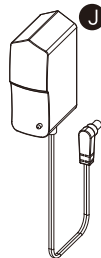
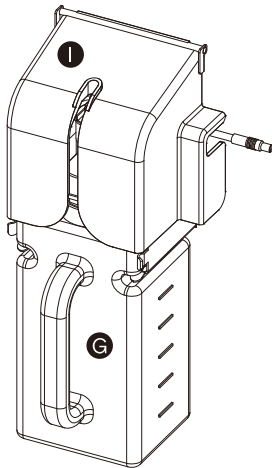

warranty

The Channel Soap Dispenser will be warranted by The Splash Lab to be free of manufacturing and material defects during normal use and environmental conditions as detailed below:

One year limited warranty

- + If a defect is found in normal use, The Splash Lab will, at their discretion, repair, provide a replacement part or product, or make appropriate adjustments. Damage caused by accident, misuse, or abuse is not covered by this warranty. Improper care and cleaning will void the warranty.
- + Non-operation of the product due to environmental conditions beyond our control, installation error, incorrect maintenance, water quality, fair wear and tear, incorrect or inappropriate installation, misuse and abuse is not covered by the warranty.
- + Proof of purchase (original sales receipt) must be provided to The Splash Lab with all warranty claims.
- + The above warranty is valid for goods supplied within North America.
- + For goods supplied outside of North America, The Splash Lab will honor the above stated warranty periods for the parts only.
- + THE SPLASH LAB DISCLAIM ANY LIABILITY FOR SPECIAL, INCIDENTAL OR CONSEQUENTIAL DAMAGES.

contact



General information

(310) 410-5008

Showroom:

8745 Washington Boulevard, Studio D, Culver City CA 90232

Warehouse + Offices:

20809 Higgins Court, Torrance CA 90501

Technical support

info.usa@thesplashlab.com

For further contact information visit:

www.thesplashlab.com/usa

