

8 7 6 5 4 3 2 1

F

F

E

E

D

D

C

C

B

B

A

A

8

7

6

5

4

3

2

1

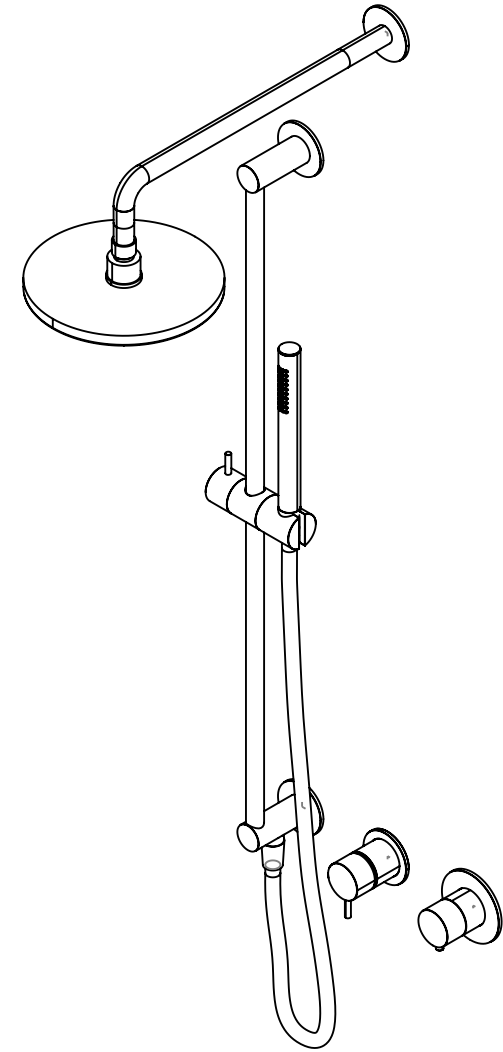
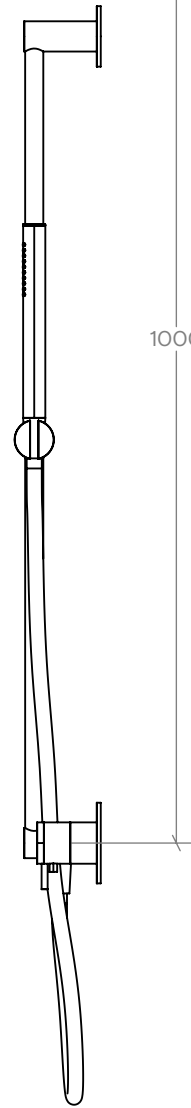
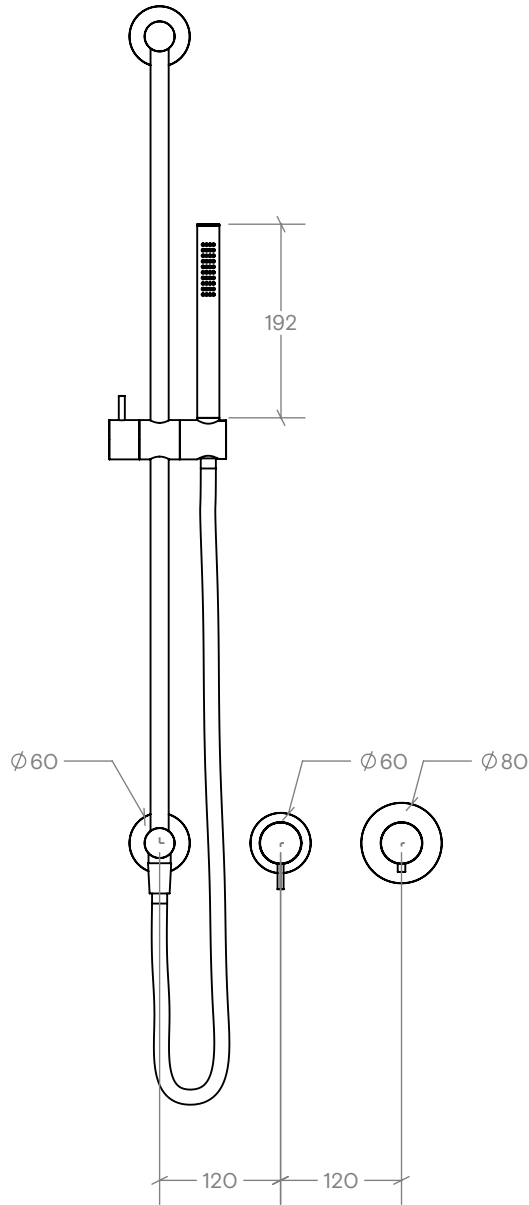
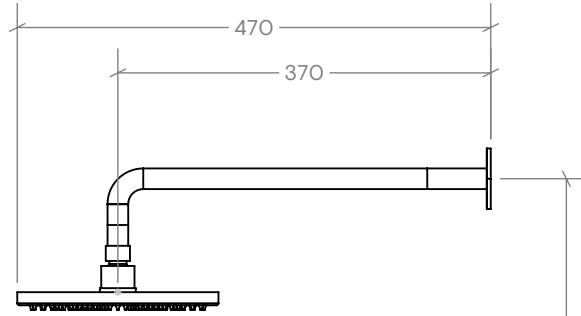
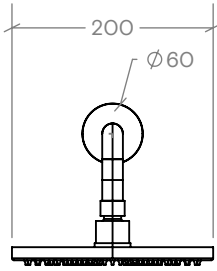

<p>UNLESS OTHERWISE SPECIFIED: DIMENSIONS ARE IN MILLIMETERS SURFACE FINISH: TOLERANCES: +/- 3MM</p> <p>PROPRIETARY AND CONFIDENTIAL THE INFORMATION CONTAINED IN THIS DRAWING IS THE SOLE PROPERTY OF THE SPLASH LAB ANY REPRODUCTION IN PART OR AS A WHOLE WITHOUT THE WRITTEN PERMISSION OF THE SPLASH LAB IS PROHIBITED</p>	PROJECT:			REVISION:
	QUANTITY:	USERS:	DATE:	TITLE:
			30/01/25	TSL.SHW.011
	MATERIAL:			
FINISH:			PRODUCT CODE - INTERNAL:	A3
			ALL DIMENSIONS, MATERIALS AND COLOURS ARE TO BE VERIFIED BY CONTRACTOR PRIOR TO PRODUCTION	DO NOT SCALE DRAWING

APPROVAL	NAME:	SIGNATURE:	DATE:
----------	-------	------------	-------