

# TSL.S051

sensor tap

installation + maintenance

+  
THE  
SPLASH  
LAB

# contents

3	Safety and Warnings
4	Box Contents
5	Technical Data
6	Before You Install
9	How to Install
11	Resetting the Sensor
13	Maintenance & Cleaning
14	Spare Parts
14	Product Identification
15	Troubleshooting
17	Troubleshooting
19	Warranty
Back Cover	Contact Details

# TSL.S051 sensor tap

## Read and save these instructions

### WARNING

To reduce the risk of fire, electric shock or injury to persons, observe the following:

- + Use this unit only in the manner intended by the manufacturer. If you have questions, contact the manufacturer.
- + This equipment should be installed in a way that ensures all electrical parts are kept dry.
- + A means of electrical isolation must be incorporated in the fixed wiring, in accordance with the current local regulations in force.
- + Disconnect the power supply before performing any maintenance on the product.
- + Children should not play with this equipment. Cleaning and maintenance shall not be performed by children without supervision.
- + This equipment is designed to be used in commercial and public areas; it is not intended for domestic or residential use.
- + Ensure wiring is installed correctly before connecting to live power supply.
- + If in doubt, consult an electrician.
- + Not to be installed above such surfaces as china or chrome drain covers.

### General information

Info.uk@thesplashlab.com  
+44 (0) 161 482 7000

### Technical support

Info.uk@thesplashlab.com

### For further contact information visit:

[www.thesplashlab.com](http://www.thesplashlab.com)

# box contents

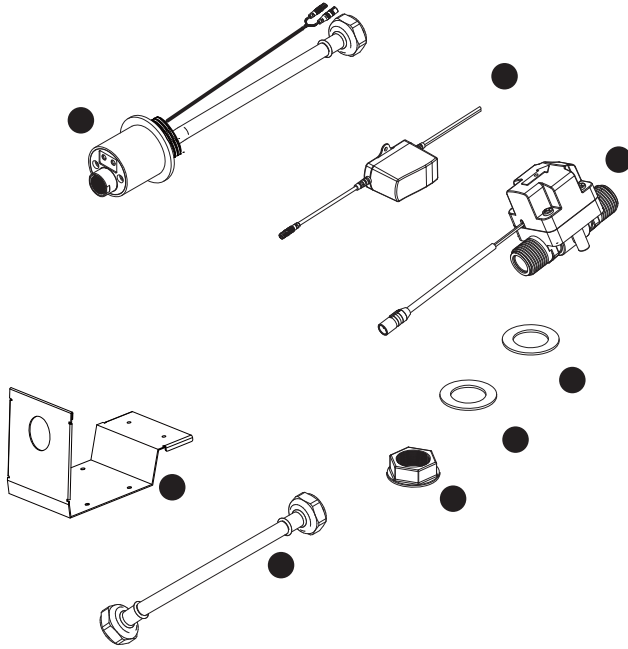

- A      Sensor tap head
- B      Mains power supply
- C      Solenoid valve
- D      Pad
- E      Gasket
- F      Fixing nut
- G      Flex hose - 300mm
- H      Bracket

# technical data

Finishes	TSL.S051.C	Bright Polished
	TSL.S051.CS	Brushed Stainless
	TSL.S051.CP	Brushed Copper
	TSL.S051.BK	Brushed Black
	TSL.S051.BR	Brushed Brass
	TSL.S051.BZ	Brushed Bronze
<hr/>		
Material (body)	316 Stainless steel	
<hr/>		
Operating pressure	7 - 87 psi dynamic pressure	
<hr/>		
Flow rate	1.9 litres/minute (Other flow rates available upon request)	
<hr/>		
Weight	1.2kg	
<hr/>		
Power supply - Mains	Input: 100-240V ac; 50/60Hz Output: 6V DC; 0.5A, 3W max	
<hr/>		
Sensor range - Preset	120±20mm	
<hr/>		
Sensor range - Minimum	50mm	
<hr/>		
Sensor range - Maximum	150mm	
<hr/>		
Comfort delay	2 seconds	
<hr/>		
Security time	60 seconds	
<hr/>		
Approvals	WRAS	
<hr/>		
Warranty	One year limited warranty	
<hr/>		

# before you install

FRONT

SIDE

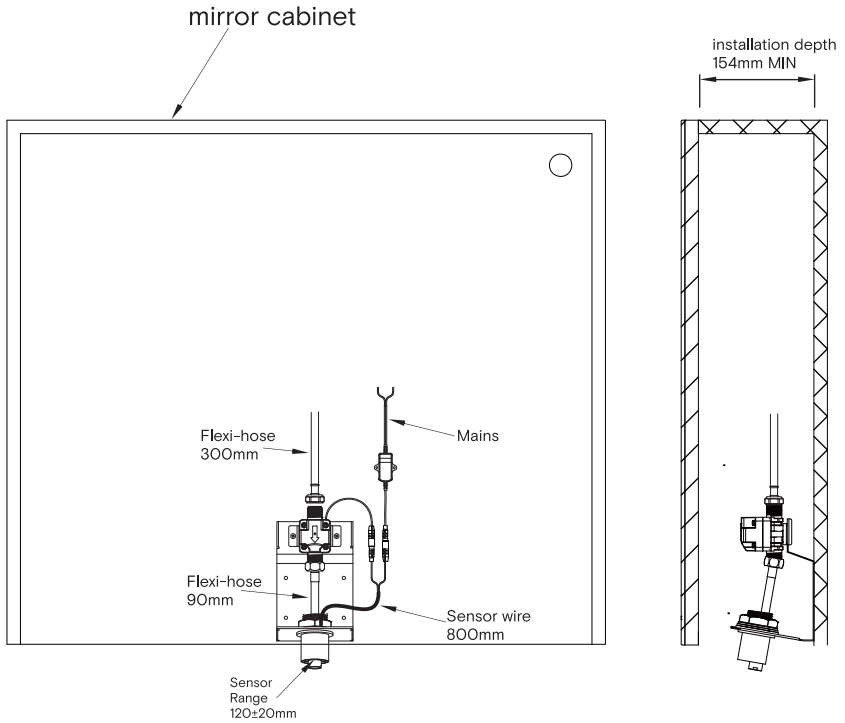

# before you install

## **Flow Rates**

---

Different flow rates may need to be achieved. The Splash Lab offers a number of flow regulators which can be used in conjunction. Contact The Splash Lab for more information.

## **Water Temperature**

---

The Tap does not come equipped with temperature control. Premixed water must therefore be supplied separately.

## **Sinks**

---

Use of a The Splash Lab monolith is recommended when used in conjunction with any of the The Splash Lab Channel fixtures.

When using other sinks, ensure that holes and appropriate mounting points are created in accordance with the diagram below.

## **Spacing**

---

If the Tap is installed with other units from the Channel System, it should be installed in the center.

# before you install

## **Basins**

---

The Splash Lab Monolith basin is recommended for products. If an alternative basin is used, please confirm with The Splash Lab that there will be no reflection or splash issue.

## **Backplate**

---

The Splash Lab offers an optional backplate for the fixtures that means the fixtures can be mounted from the front and have simpler access.



# how to install

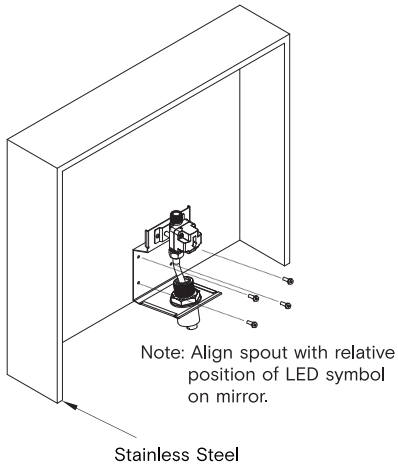

## 1

When installing the tap in a stainless steel cabinet, first drill four installation holes at the appropriate position in the cabinet then fasten the tap with four screws.

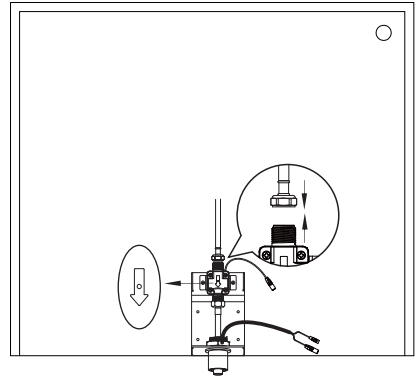

## 2

Fasten the water inlet tube to the other end of the solenoid valve.

# how to install

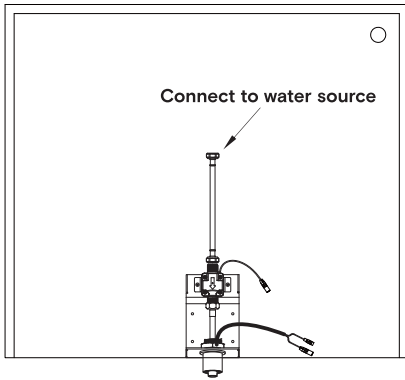

**3**

Fasten the water inlet hose to the connect of water source.

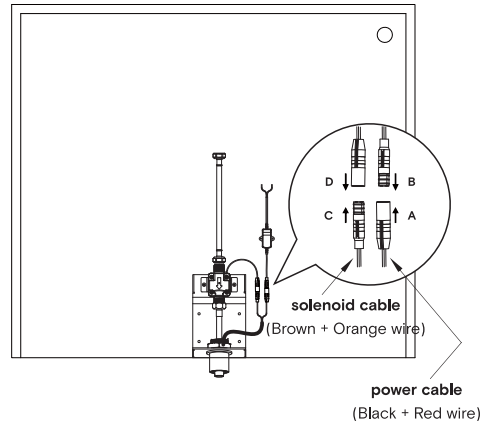

**4**

Connect the power cable A to power cable B. Connect the solenoid cable C to solenoid cable D.

# resetting the sensor

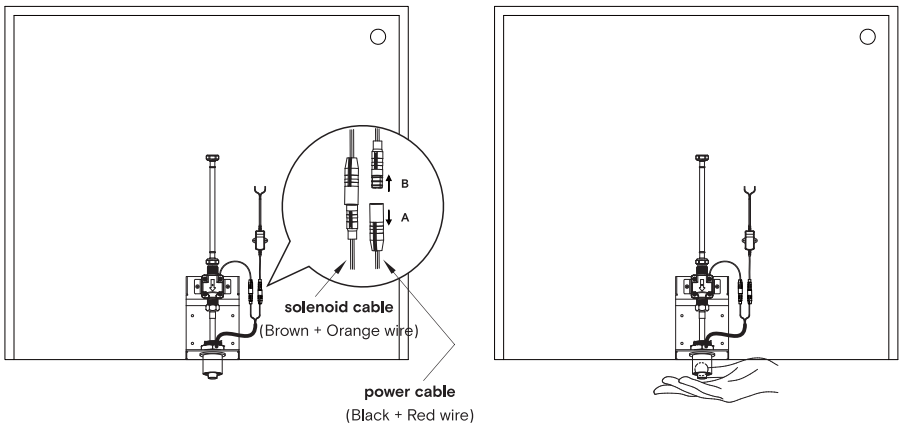

**1**

First disconnect the tap head from the Power unit. Wait a minimum of 4 seconds and reconnect the power.

**2**

After connecting to power, immediately place your hand at about 50mm below the sensor on the tap head and keep it there for 3 seconds.

# resetting the sensor

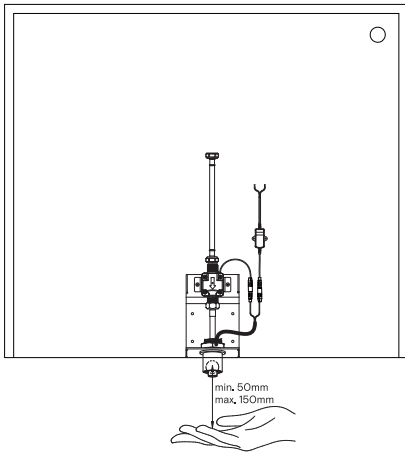

## 3

At the end of the 3 seconds, move your hand away from the sensor and down towards the wash basin to set the desired sensor range (min. 50mm / max. 150mm) and keep your hands at the desired position for 3 seconds.

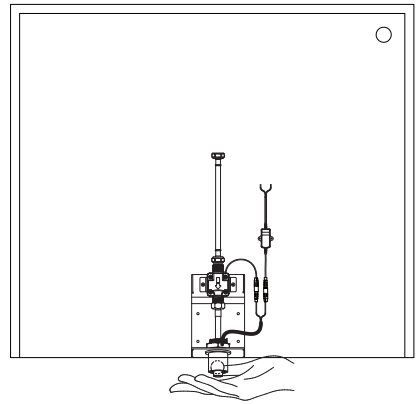

## 4

At the end of 3 seconds, move your hand back to the original 50mm position from the sensor and keep at the position for 3 seconds to complete setting up the desired sensor range.

\*Remove reflective clothing during installation.

# **maintenance & cleaning**

\*Isolate the unit from the power supply before any servicing or maintenance work is carried out.

## **How to clean the spout of tap and how regularly**

---

- + Please use a clean cloth to wipe away the dusts and/or water mark on the spout or use a damp cloth to clean it. It is recommended to clean the spout every six months, depending on the frequency of usage and environment.
- 

## **How to clean the valve and how regularly**

---

- + Please cut off the power, turn off the water inlet and remove the valve. Clean the filter on the valve with a soft brush. It is recommended to clean the valve every six months, depending on the frequency of usage and environment.
- 

## **What should NOT be used**

---

- + Do not use steel brush or abrasive that could scratch the spout.
- 

## **Best care for PVD Finishes**

---

- + You can clean the PVD finished spout with a damp cloth and water. Do not use cleaning solution or liquid alcohol.
-

# spare parts

If a situation arises where you require replacement components outside of a maintenance contract, there may be provision to obtain spare parts. Providing the components are under warranty and the parts have become non-functioning during normal use within their assumed usable life, they may be replaced. Should a replacement mains power supply be required it is imperative that an identical type is used. Contact The Splash Lab for further information.

# product identification

A unique product identification code can be found on the product tag attached to the water hose.

# troubleshooting

## **Corrective Actions for Initial Installation Failures**

---

### **Water does not flow / Cannot hear valve open**

---

- + There is no power to valve or sensor.
- + Check that cables are connected.
- + Check that transformer is operating and supplying 6 volts.
- + Sensor range is incorrect.
- + Adjust sensor setting. (see pages 11 and 12)

### **Water does not flow / Valve can be heard to open**

---

- + Water supply is blocked to valve.
- + Check and clean filter on solenoid valve.
- + Check water supply for any blockages or restrictions.
- + Water pressure is too low.
- + Check pressure of water supply.

### **Water does not flow / Sensor light is flashing all the time**

---

- + Supply voltage has dropped below 5.4V.
- + Check power supply and if necessary replace the power wire.

# troubleshooting

## Corrective Actions for Initial Installation Failures

---

### Water runs nonstop

---

- + Ensure the protrusions on each solenoid cable connector aligns with each other. If the solenoid cables are not connected properly, nonstop water flow may occur. Please see page 10 for instructions.
- + Ensure the solenoid valve is installed with the side arrow pointing down. See page 9 for instructions.
- + Remove any obstruction below the sensor.

## Corrective Actions for In-Service Failures

---

### Water runs nonstop

---

- + If water trickles non-stop, change the solenoid valve.
- + If water flows non-stop at normal flow rate, change the solenoid valve or the sensor.

### Water flow is reduced

---

- + Clean the solenoid valve filter.

We are always looking to improve. If these did not solve your problem please contact us and we will endeavour to help.

Tel: +44 (0) 161 482 7000

Email: [Info.uk@thesplashlab.com](mailto:Info.uk@thesplashlab.com)



# warranty

**The Sensor Tap** will be warranted by The Splash Lab to be free of manufacturing and material defects during normal use and environmental conditions as detailed below:

One year limited warranty

- + If a defect is found in normal use, The Splash Lab will, at their discretion, repair, provide a replacement part or product, or make appropriate adjustments. Damage caused by accident, misuse, or abuse is not covered by this warranty. Improper care and cleaning will void the warranty.
- + Non-operation of the product due to environmental conditions beyond our control, installation error, incorrect maintenance, water quality, fair wear and tear, incorrect or inappropriate installation, misuse and abuse is not covered by the warranty.
- + Proof of purchase (original sales receipt) must be provided to The Splash Lab with all warranty claims.
- + The above warranty is valid for goods supplied within the U.K. & Europe.
- + For goods supplied outside of U.K. & Europe, The Splash Lab will honor the above stated warranty periods for the parts only.
- + THE SPLASH LAB DISCLAIM ANY LIABILITY FOR SPECIAL, INCIDENTAL OR CONSEQUENTIAL DAMAGES.





# contact



## General information

Info.uk@thesplashlab.com  
+44 (0) 161 482 7000

## Technical support

Info.uk@thesplashlab.com

**For further contact information visit:**

[www.thesplashlab.com](http://www.thesplashlab.com)

TSL\_S051 • (EUR) • REV 0-10/05/24

