

TSL.940 / TSL.980

deck mounted sensor tap

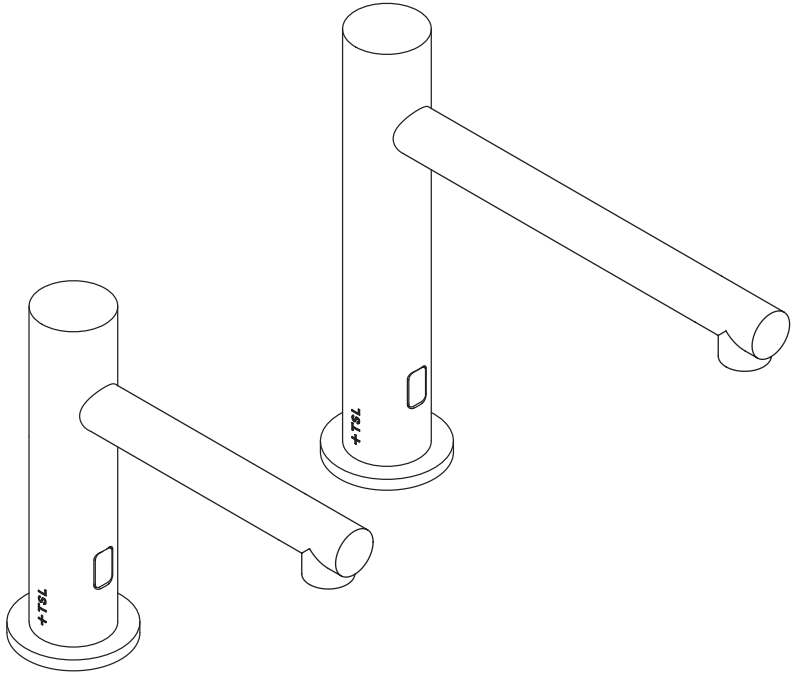

installation + maintenance

+ THE
SPLASH
LAB

contents

3	Safety and Warnings
4	Box Contents
5	Diagram
6	Technical Data
8	Before You Install
9	Technical Drawing
11	How To Install
15	Commissioning & Operation
16	Troubleshooting
17	Cleaning
18	Maintenance
19	Warranty
Back Cover	Contact Details

TSL.940 / TSL.980

Read and save these instructions

WARNING

To reduce the risk of fire, electric shock or injury to persons, observe the following:

- + Use this unit only in the manner intended by the manufacturer. If you have questions, contact the manufacturer (see back page for more details).
- + Ensure plumbing is installed correctly before activating water supply.
- + All plumbing is to be installed in accordance with applicable codes and regulations.

For more information contact:

Tel: +44 (0)161 482 7000

Email: technical@thesplashlab.com

box contents

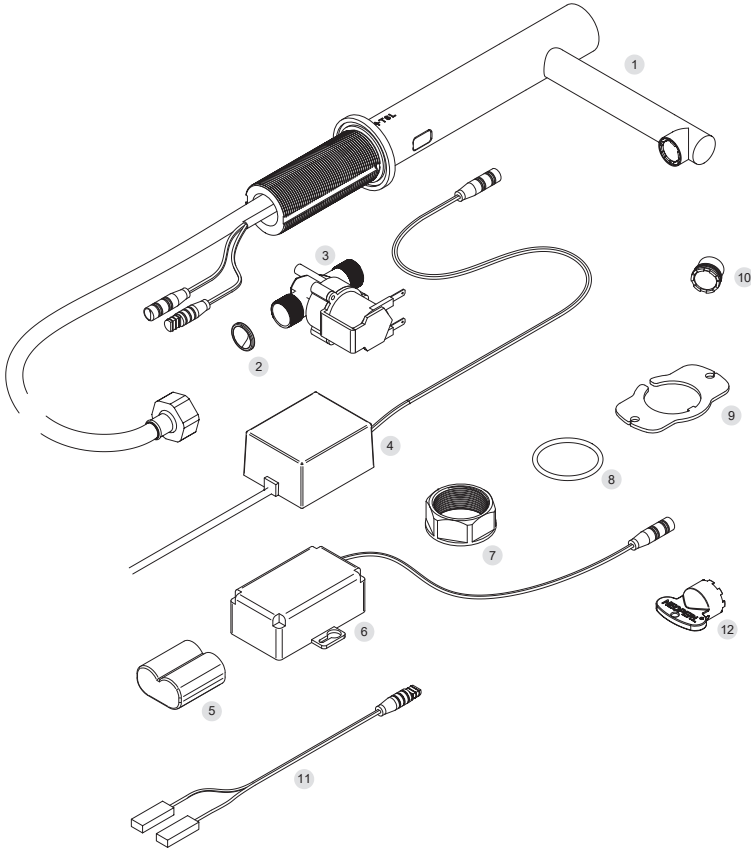

	TSL.940.ELE	TSL.980.ELE	TSL.940.BAT	TSL.980.BAT
1 Tap assembly	-	-	-	-
2 Inline filter / strainer	TSLP.08530015	TSLP.08530015	TSLP.08530015	TSLP.08530015
3 Solenoid valve	TSLP.120030	TSLP.120030	TSLP.120030	TSLP.120030
4 Mains power supply unit	TSLP.270066	TSLP.270066	-	-
5 Battery	-	-	TSLP.270030	TSLP.270030
6 Battery holder	-	-	TSLP.270029	TSLP.270029
7 Backnut	TSLP.900.020	TSLP.900.020	TSLP.900.020	TSLP.900.020
8 Base O-ring	TSLP.104	TSLP.104	TSLP.104	TSLP.104
9 Anti-rotation plate	TSLP.900.000	TSLP.900.000	TSLP.900.000	TSLP.900.000
10 Aerator - 1.89lpm - Spray pattern	TSLP.260063	TSLP.260063	TSLP.260063	TSLP.260063
11 Solenoid connector cable	TSLP.120032	TSLP.120032	TSLP.120032	TSLP.120032
12 Aerator key	TSLP.260050	TSLP.260050	TSLP.260050	TSLP.260050

diagram

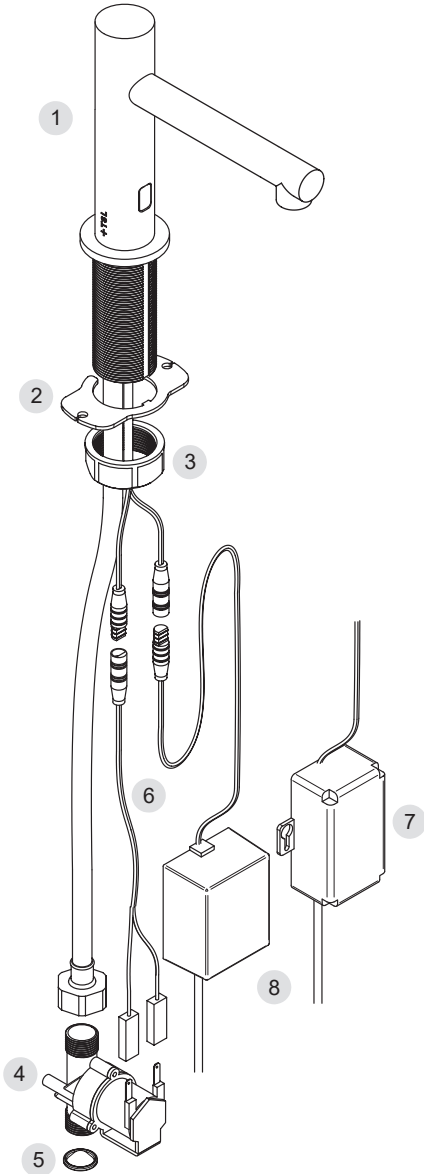

- 1 Tap assembly
- 2 Anti-rotation plate
- 3 Backnut
- 4 Solenoid valve
- 5 Inline filter / strainer
- 6 Solenoid connector cable
- 7 Mains power supply unit
- 8 Battery holder

technical data

Overview

The TSL.940 and TSL.980 is a stainless steel deck mounted sensor tap, available in a variety of coloured finishes, with a sleek and minimalist design.

Codes	Power	Finishes
TSL.940/980.CS.BAT	Battery	Brushed Stainless Steel
TSL.940/980.CP.BAT	Battery	Brushed Copper
TSL.940/980.BK.BAT	Battery	Brushed Black
TSL.940/980.BR.BAT	Battery	Brushed Brass
TSL.940/980.BZ.BAT	Battery	Brushed Bronze
TSL.940/980.CS.ELE	Mains	Brushed Stainless Steel
TSL.940/980.CP.ELE	Mains	Brushed Copper
TSL.940/980.BK.ELE	Mains	Brushed Black
TSL.940/980.BR.ELE	Mains	Brushed Brass
TSL.940/980.BZ.ELE	Mains	Brushed Bronze

Light Reflectance Values

Brushed Stainless Steel	58
Brushed Copper	19
Brushed Black	3
Brushed Brass	40
Brushed Bronze	17

Technical Data: Mechanical

Body Material	AISI 304 Stainless Steel
Coating Type	PVD (colours only)
Weight	1.4Kg
Aerator	Cascade flow
Min/Max pressure	0.5 – 7.5 bar
Flow Rates	3.8l/min [0.5gpm]
	Also available as optional extras:
	1.35l/min [0.35gpm]
	1.89l/min [0.5gpm]
Max Hot Water Temperature	60°C

technical data

Technical Data: Electrical

Power Supply (Battery)	6V CR-P2 Lithium Battery
Power Supply (Mains)	100-240V; 1.5A; 50-60Hz PSU.
Output (Max)	6V; 6W max
Power Consumption	< 80 μ A
Solenoid Valve	6V
Water Ingress (PSU)	IP67
Cable Lengths	Connection to sensor cable - 400mm Connection to fused supply - 1.5m

Technical Data: Sensor

Sensor Type	Infra red
Pre-set Sensor Range	120mm
Maximum Sensor Range	250mm
Comfort Delay	2 seconds
Security Time-out	30 seconds
Operating Temperature	0 to 50°C
Response Time (max)	< 300ms

Compliance

WRAS	Certificate 2012304
CE	PSU conforms to RoHS, REACH, EN15091
BREEAM	Qualities for up to 5 credits as part of water efficiency assessment

before you install

Caution



- + The TSL.940 / TSL.980 parts must be put together correctly before installation.
- + All parts must be installed correctly before powering up the system.

Access Requirements

It is critical all components which require fixing behind the wall are easily accessible at all times during installation and routine maintenance.

Front access: If the underside of the wash basin is tiled in, or is fixed onto a vanity unit, a front hatch or panel(s) must be constructed below the wash basin for ongoing maintenance access.

Access Requirements

1. A pre-mixed water supply is required that complies with the current local plumbing regulations.
2. A minimum dynamic water pressure of 0.5bar is required for valve to function. Gravity-fed installations may require the installation of a booster pump to achieve the optimum operating pressure.
3. All pipework must be flushed through prior to the tap being connected to ensure all debris is clear and will not enter the tap. Chlorination of the building system must also be performed prior to connection of the tap.
4. For mains powered taps, a 3A fused power supply is required. If required, multiple PSUs can be connected to the mains supply if the fuse is upgraded accordingly.

technical drawing

TSL.980

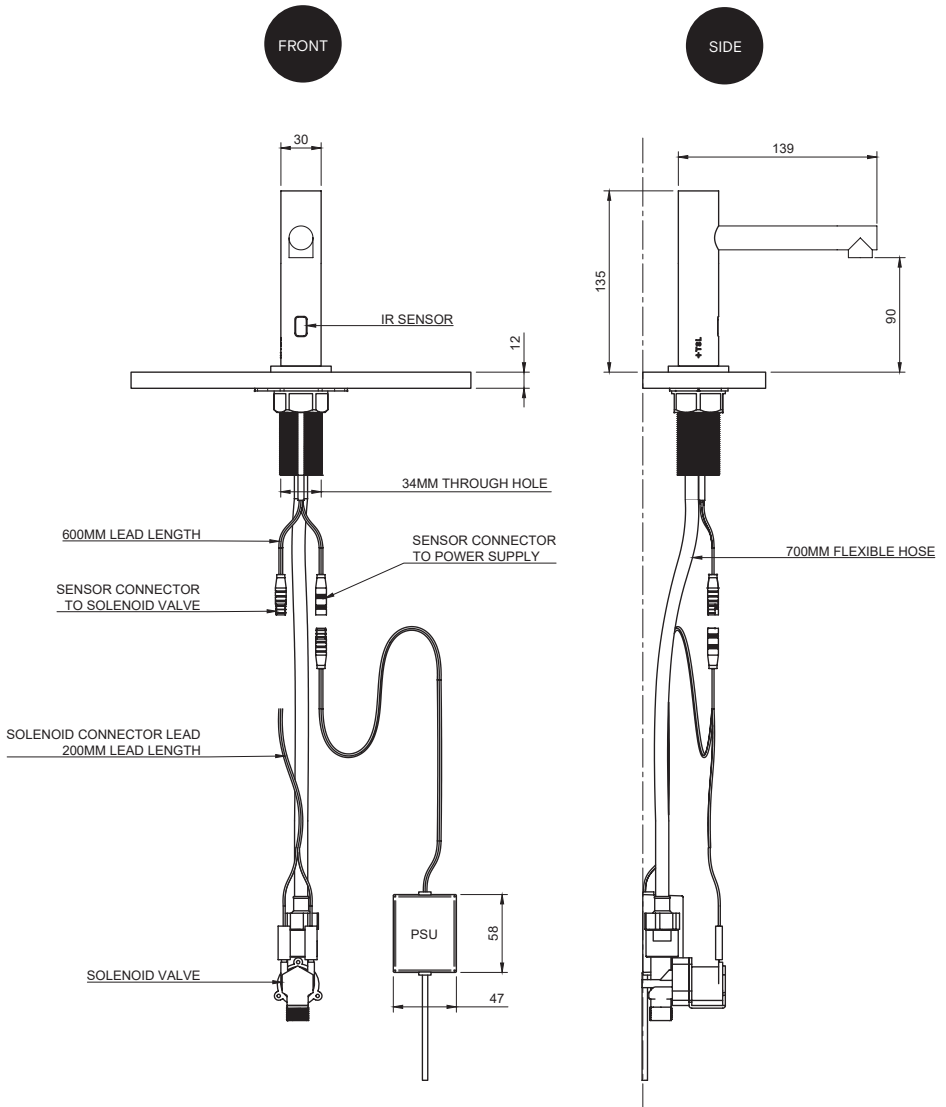

technical drawing

TSL.940

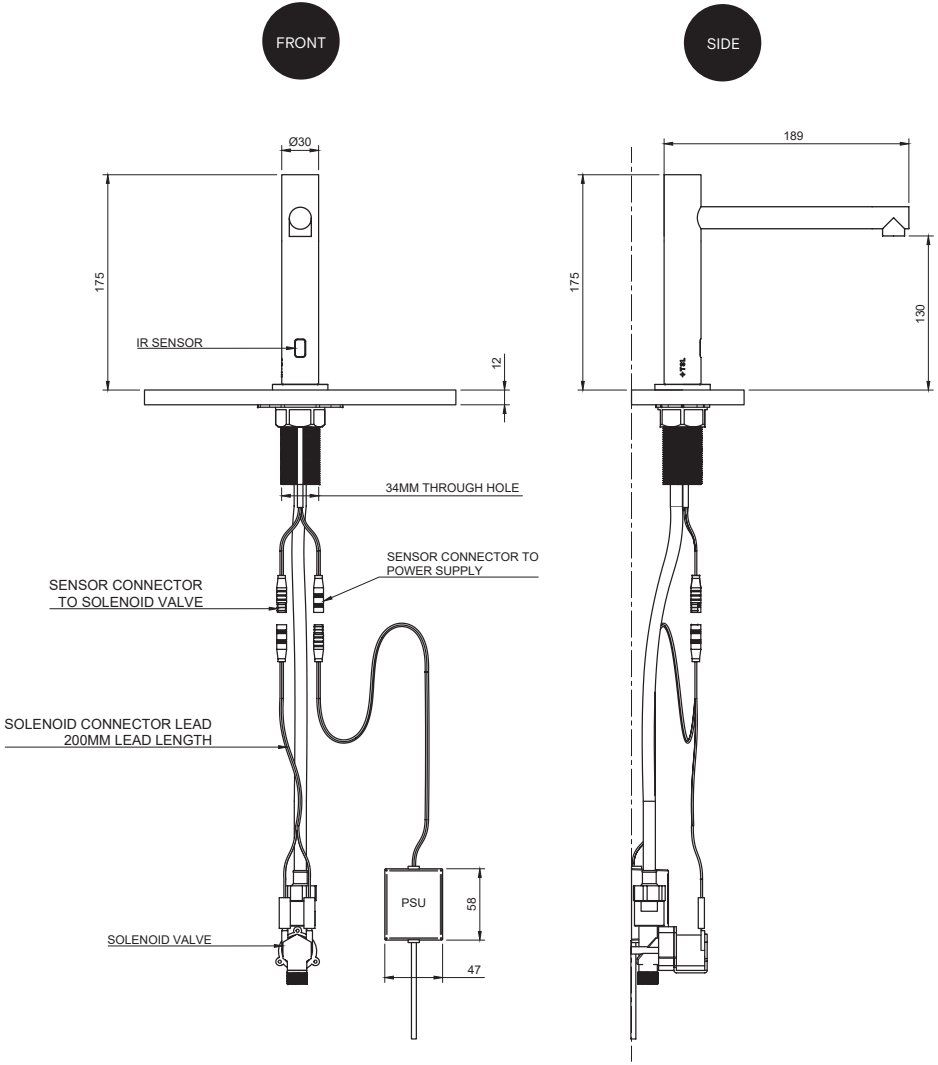

how to install

Tap Installation

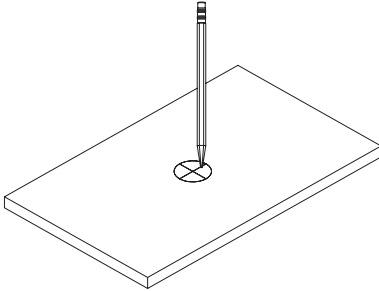

1
Mark tap hole centre onto the surface for installation.

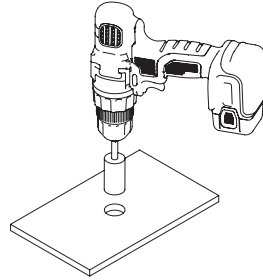

2
For countertop fitment, drill 35mm diameter hole in countertop.

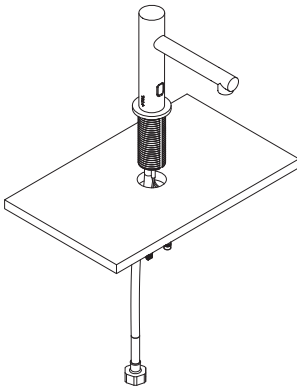

3
Insert the tap through hole in basin or countertop.

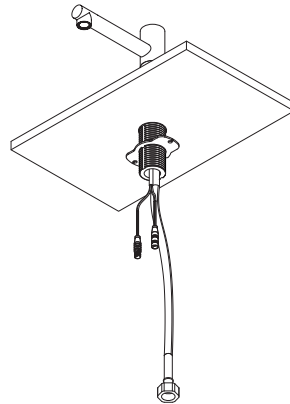

4
Slide the anti-rotation plate and fixing nut over flexi hose and sensor cable and onto mounting shank.

Tap Installation

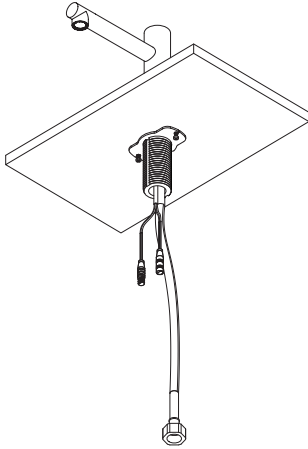

5

Using fixings suitable to your application, fix the anti rotation plate using the holes provided.

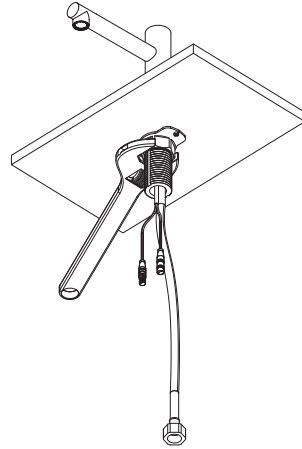

6

Slide the backnut over the flexible hose and sensor leads. Tighten using a spanner.

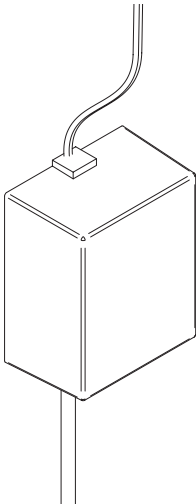

7

Position the power supply to the underside of the unit. Before fixing into place ensure cables can reach connector positions.

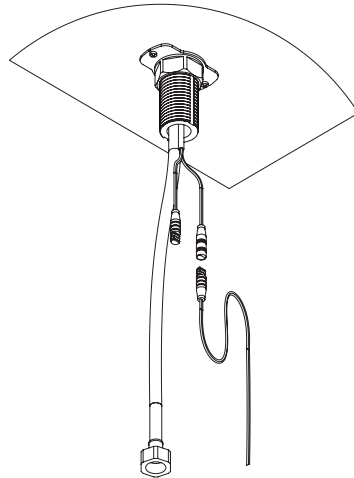

8

Connect the power supply cable to the sensor cable.

Tap Installation

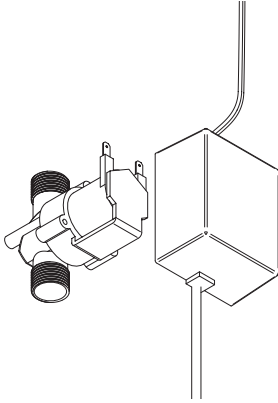

9

Position the solenoid valve to the underside of the unit. Before fixing into place, ensure cables can reach the connector positions.

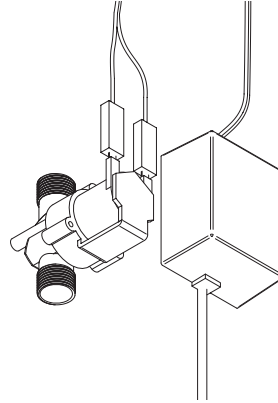

10

Connect the solenoid cable connector leads to the solenoid valve, observing the correct polarity of the terminals.

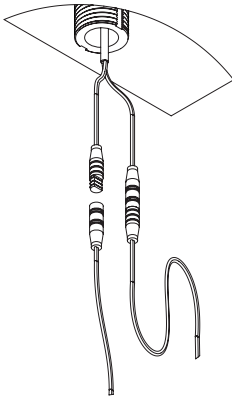

11

Connect the solenoid cable connector to the sensor connector.

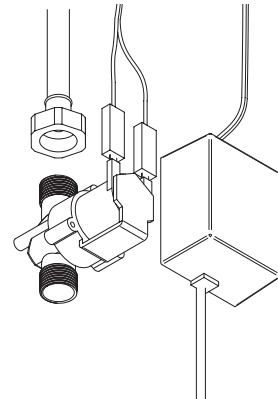

12

Fit the flexible hose nut onto the solenoid adapter

Tap Installation

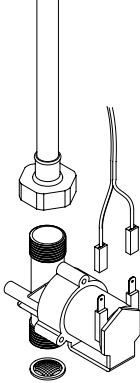

13

Insert conic filter into inlet side of valve and connect to water supply. The filter must be fitted, otherwise the warranty may be invalid.

14

Once all nuts are tightened, open the water inlet and allow water to flow.

WARNING: Ensure all connections are fully tightened to ensure full seal of the tap.

15

The product is now ready to be wired into the spur and tested and commissioned accordingly.

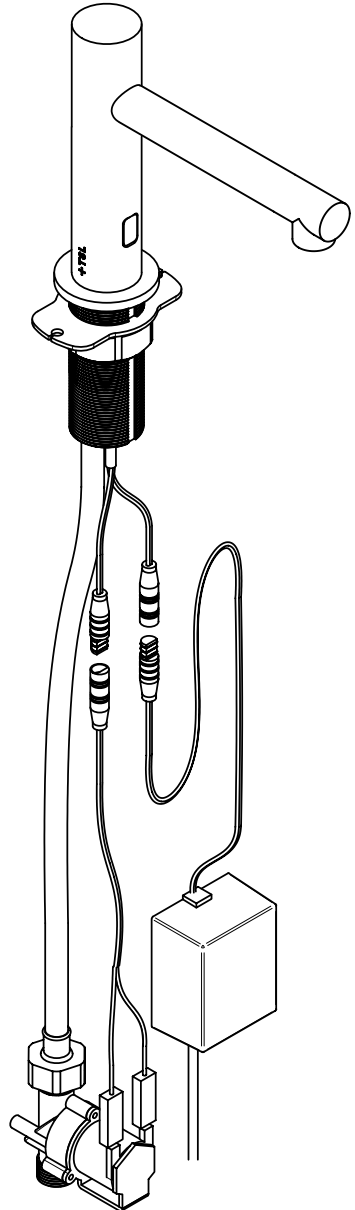

commissioning

- + Connect the water supply (turn isolation valve on)
- + Turn power supply on and wait 20 seconds
- + Activate the sensor by placing hand within detection range, and water will flow.

Adjusting the sensor range:

The sensor range can be adjusted if required to suit the installation conditions.

1. Disconnect the power supply (battery or mains).
2. Wait a few seconds and reconnect the power supply.
3. Position your hand less than 5cm in front of the sensor whilst the LED flashes.
4. When the LED is continuously lit (and no longer flashing), position your hand at the new detection distance.
5. Wait until the LED goes out before removing your hand.
6. When the LED goes out the new detection distance will be set.

operation

The user is to activate the tap by placing their hands within the range of the infra-red sensor, to cause the solenoid valve to open for a preset time. The valve will close a set time after the user's hands have been removed from the detection range.

troubleshooting

Problem	Cause	Solution
Water not flowing	Range is too short	Increase detection range.
	Range is too long	Decrease detection range.
	Sensor is dirty or obstructed.	Clean sensor and remove obstruction.
	Tap is in security time-out mode.	Replace batteries or restore power supply.
	Solenoid valve is incorrectly connected (polarity reversed).	Reconnect solenoid valve with correct polarity.
	Sensor is detecting reflections from basin or another object.	Reduce detection range or remove object causing reflection.
Water flow does not stop when user's hands are within range	Debris or scale in solenoid valve.	Remove solenoid and clean or replace valve.
	Cables between PSU and solenoid are disconnected.	Reconnect cables.
	Solenoid valve is incorrectly connected (polarity reversed).	Reconnect solenoid valve with correct polarity.
	Water supply pressure is too high.	Reduce water pressure.
Slow response time when opening or closing solenoid valve	Cable connections loose.	Check all connections are properly fitted together.
	Debris or scale in solenoid valve.	Remove solenoid and clean and replace valve.
	Sensor is detecting reflections from basin or other object.	Reduce detection range or remove object causing reflection.
Water flow reduced	Aerator is blocked with scale or debris.	Remove aerator and clean or replace.
	Debris or scale in solenoid valve.	Remove solenoid and clean and replace valve.

cleaning

- + Take extra care when cleaning decorative surfaces.
- + For surface cleaning of the tap use ONLY soap and water, then wipe dry with a clean cloth or towel.
- + DO NOT use steel wool or cleaning agents containing alcohol, acid, abrasives or the like.
- + Use of any prohibited cleaning or maintenance products or substances could damage the surface of the tap.
- + When cleaning bathroom tiles, the taps should be protected from any splattering of harsh cleansers.

All grades of stainless steel will stain or discolour if due care and attention is not taken. The surface must be regularly cleaned to ensure a long service life of the tap.

Use a soft cloth or sponge with a mild solution of soapy water as part of the regular washroom janitorial routine. Do not use abrasive or cream cleaners as these will damage the surface finish.

If further information is required, contact The Splash Lab technical team for more detailed stainless steel care guidelines.

maintenance

1. Shut off the water supply to the tap.
2. Disconnect the solenoid cable from the power supply.
3. Disconnect the solenoid valve from the brass reducing adaptor and the brass fitting attached to the mains water supply.
4. Remove the filter from the faulty solenoid valve.
5. Re-fit new filter to replacement solenoid valve.
6. Reassemble the parts as shown.
7. Restore the incoming water supply checking there are no water leaks.
8. Reconnect the solenoid cable to the power supply.

Note: the directional flow of water is shown on the solenoid housing with an arrow.

warranty

We believe the future is personal. With a global mindset, we challenge conventional washroom norms via product innovation to create considered washroom solutions for corporate, public and hospitality spaces. We use rich raw materials, cutting-edge automation and considered washroom design to powerfully and positively influence the lives of people.

Demonstrating our commitment to quality and our belief in the strength of our designs, we offer the following warranties.

The Splash Lab warrant that its products will be free of manufacturing and material defects during normal use and environmental conditions as detailed below:

Sensor taps 2 years parts & labour

If a defect is found in normal use, The Splash Lab will, at their discretion, repair, provide a replacement part or product, or make appropriate adjustments. Damage caused by accident, misuse, or abuse is not covered by this warranty. Improper care and cleaning will void the warranty.

Non-operation of the product due to environmental conditions beyond our control, installation error, incorrect maintenance, water quality, fair wear and tear, incorrect or inappropriate installation, misuse and abuse is not covered by the warranty.

Proof of purchase (original sales receipt) must be provided to The Splash Lab with all warranty claims.

The above warranty is valid for goods supplied within the United Kingdom.

For goods supplied outside of the United Kingdom, The Splash Lab will honour the above stated warranty periods for the parts only.

THE SPLASH LAB DISCLAIM ANY LIABILITY FOR SPECIAL, INCIDENTAL OR CONSEQUENTIAL DAMAGES.

contact



General information

info.uk@thesplashlab.com

+44 (0) 161 482 7000

Technical support

technical@thesplashlab.com

For further contact information visit:

www.thesplashlab.com

