

# TSL.C041

channel soap dispenser

installation + maintenance

+  
THE  
SPLASH  
LAB

# contents

3	Safety and Warnings
4	Box Contents
5	Technical Data
6	Before You Install
8	How to Install
13	Operation
13	Spare parts
14	Maintenance & Cleaning
15	Troubleshooting
16	Diagram
17	Warranty
Back Cover	Contact Details

# TSL.CO41 channel soap dispenser

Read and save these instructions

**WARNING** 

To reduce the risk of fire, electric shock or injury to persons, observe the following:

- + Use this unit only in the manner intended by the manufacturer. If you have any questions, contact the manufacturer.
- + This equipment should be installed in a way that ensures all electrical parts are kept dry.
- + A means of electrical isolation must be incorporated in the fixed wiring, in accordance with the current local regulations in force.
- + Disconnect the power supply before performing any maintenance on the product.
- + Children should not play with this equipment. Cleaning and maintenance shall not be performed by children without supervision.
- + This equipment is designed to be used in commercial and public areas; it is not intended for domestic or residential use.
- + Ensure wiring and cover is installed correctly before connecting to live power supply.
- + If in doubt, consult an electrician.

## General information

Info.uk@thesplashlab.com  
+44 (0) 161 482 7000

## Technical support

Info.uk@thesplashlab.com

**For further contact information visit:**

[www.thesplashlab.com](http://www.thesplashlab.com)

# box contents

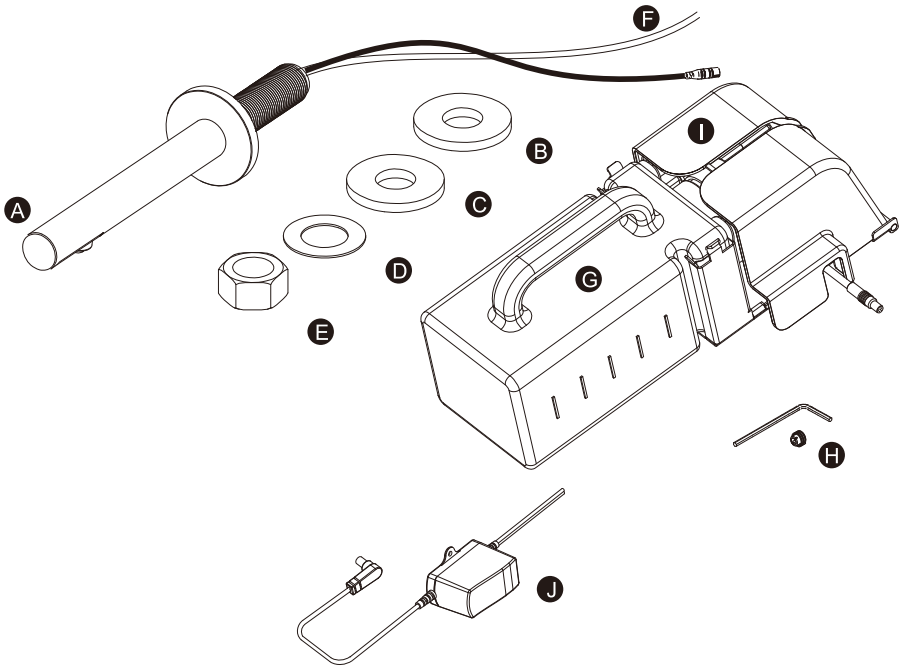

A	Dispenser head assembly
B	Pad (already installed)
C	Gasket
D	Washer
E	Fixing nut
F	Soap foaming pipe - 1000mm
G	Soap reservoir - 1500ml
H	Hex wrench/ Soap outlet
I	Soap foamer pump unit
J	Power supply unit

# technical data

Finishes	TSL.CO41.C	Bright Polished
	TSL.CO41.CS	Brushed Stainless
	TSL.CO41.CP	Brushed Copper
	TSL.CO41.BK	Brushed Black
	TSL.CO41.BR	Brushed Brass
Power supply - Mains	Input: 100-240V ac; 50/60Hz Output: 6V DC; 1.5A, 9W max	
Power supply - Battery	6V Type AA x 4 pcs Alkaline (not included) (Optional)	
Standby power	9mA	
Weight	1.5kg	
Material	316 Stainless steel	
Sensor range	70±15mm (Not adjustable)	
Recommended soap viscosity	Foam soap - <10cPs. Not suitable for alcohol gels or hand sanitizers.	
Approvals	CE, UKCA, RoHS	
Warranty	One years limited warranty	

# before you install

## Basins

The Splash Lab Monolith basin is recommended for use with the Channel range of products. If an alternative basin is used, please confirm with The Splash Lab that there will be no reflection of splash issue.

## Spacing

If the Channel Soap Dispenser is installed with the Channel Tap, it should be 150mm to the left of the Tap, which is at the centre. The Channel Dryer should be 200mm to the right of the Tap.

## Backplate

The Splash Lab offers an optional backplate for the fixtures that means they can be mounted from the front and have simpler access.

## Front view

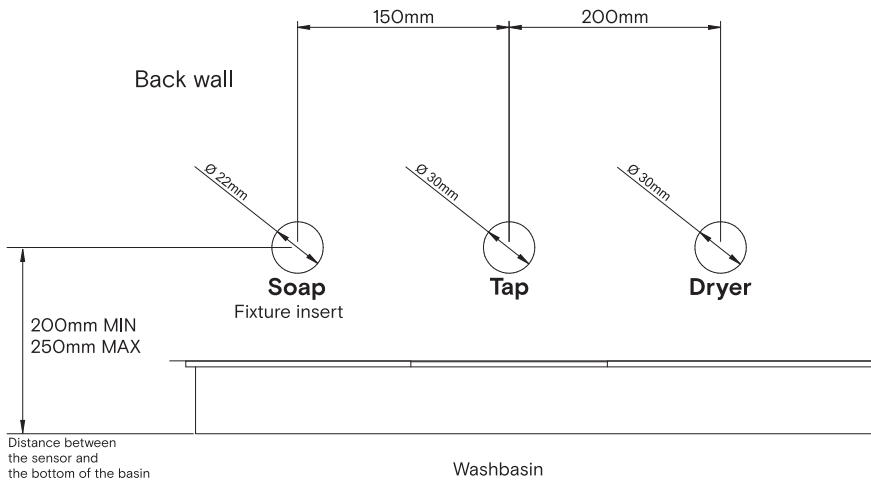

# before you install

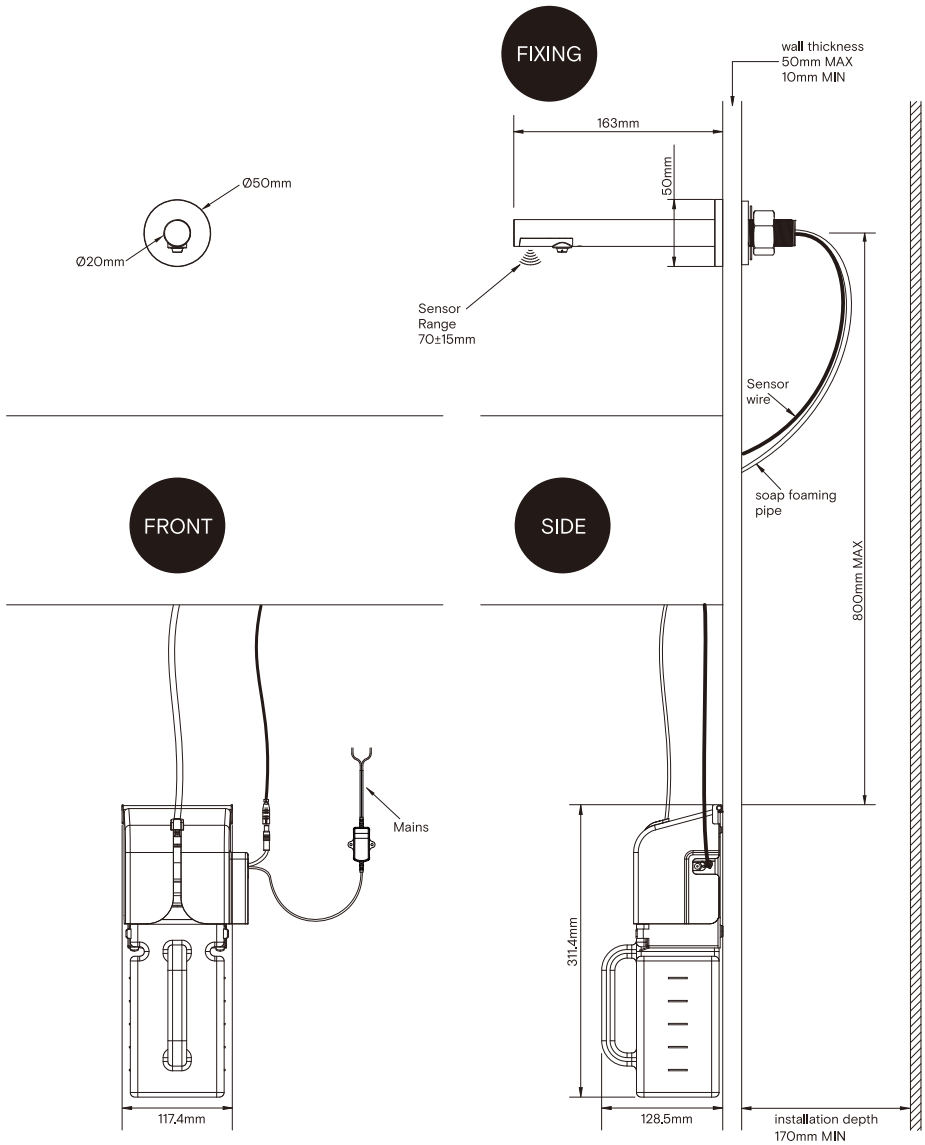

# how to install

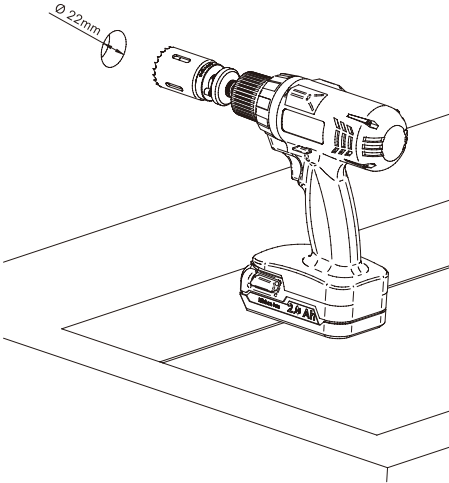

**1**

Drill hole 22mm diameter in wall  
200–250mm above the bottom of the  
basin.

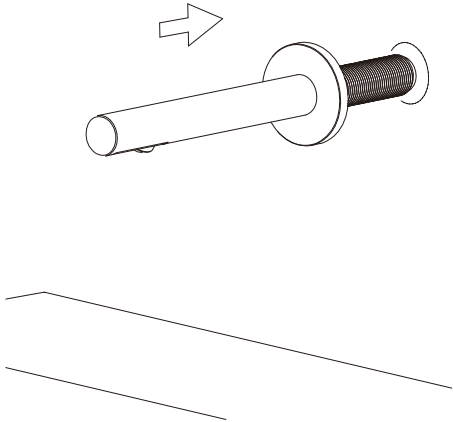

**2**

Fit dispenser body into the 22mm hole in wall.



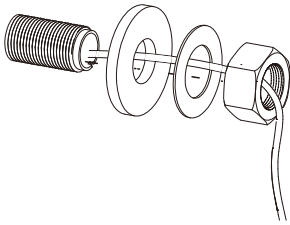

### 3

The sensor wire and soap foaming pipe through the gasket, washer and fixing nut. Tighten the nut against the installation wall.

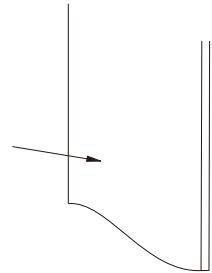
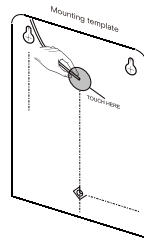
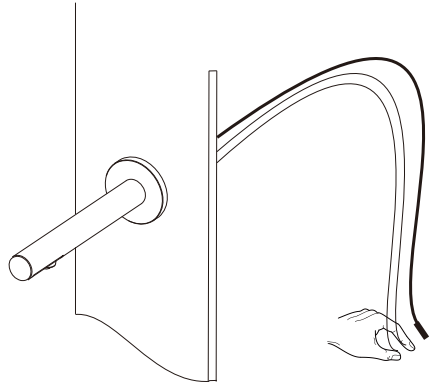

### 4

Place Mounting template on the wall below the basin or behind the UT wall to find the best position for installing.

# how to install

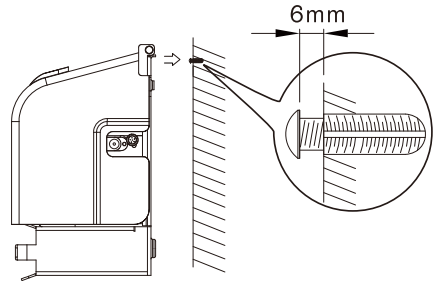
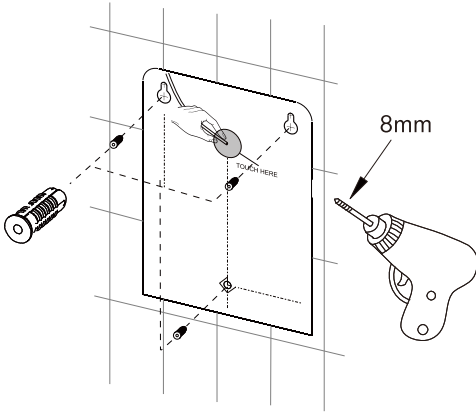

## 5

Put the mounting template in the best installation position on the wall according to the position of the holes in the mounting template. Then drill 3 holes (size: 8mm) and put the 3 wall plugs, included in kit, in the holes. Contractor may use other size.

## 6

Screw two screws into the top wall plugs, but leave a 6mm space between the head of the screw and wall, so the control box assembly can hang properly.

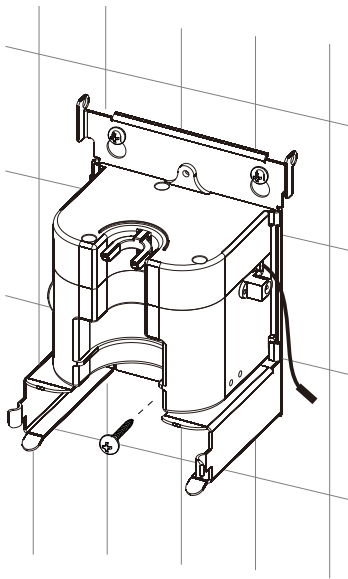

**7**

When the control box assembly has been hung on the wall, fasten the third screw into the bottom wall plug.

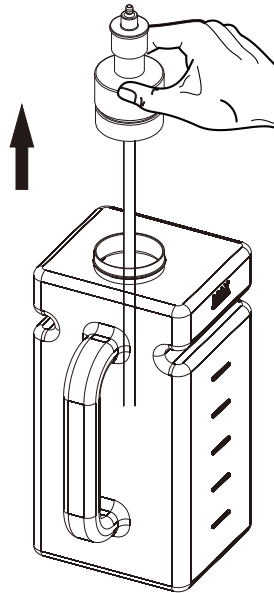

**8**

Pull up the soap pump, fill in the foam soap and then push down the soap pump until you hear it snap into place.

# how to install

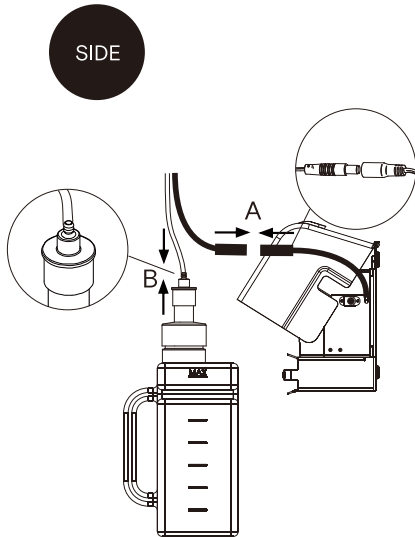

## 9

Connect the wire of the soap dispenser to the wire of the control box assembly. Connect the tube of the soap dispenser to the connector on the soap pump. The overall length of the soap tube is 1000mm. For a suitable length for installation, cut the tube as short as possible to save battery life and to improve soap volume.

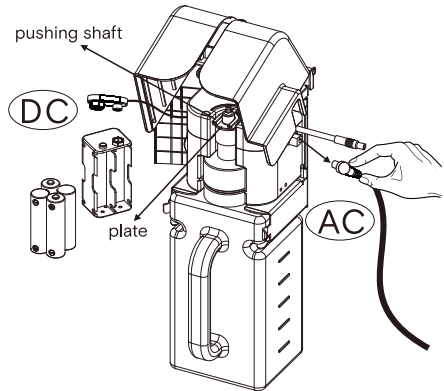

## 10

Push the soap tank to the track. Make sure the soap pump plate is under the pushing shaft before you put back the soap tank, so the soap dispenser can work properly. Connect the fuse spur to power mains or plug-in battery box to supply power. Installation finished.

\*To use power mains as the power source, do not place batteries in the battery compartment.

To use batteries as the power source, insert the batteries in the battery compartment and disconnect the AC power wire from the control box. The life cycle of the soap dispenser based on using batteries as the power source is about 15,000 cycles.

# operation

- + The user places hands within the detection range of the sensor to activate the soap dispenser.
- + The motor will start and soap is dispensed onto the user's hands.

# spare parts

If a situation arises where you require replacement components outside of a maintenance contract, there may be provision to obtain spare parts. Providing the components are under warranty and the parts have become non-functioning during normal use within their assumed usable life, they may be replaced. Should a replacement mains power supply be required it is imperative that an identical type is used. Contact The Splash Lab for further information.

# **maintenance & cleaning**

\*Isolate the unit from the power supply before any servicing or maintenance work is carried out.

---

## **How to clean the spout of soap dispenser and how regularly**

- + Please use a clean cloth to wipe away the dusts and/or water mark on the spout or use a damp cloth to clean it. It is recommended to clean the spout every six months, depending on the frequency of usage and environment.
- 

---

## **How to clean the soap tank and how regularly**

- + Remove the soap tank, rinse with running water. It is recommended to clean the soap tank every three months, depending on the soap type used, frequency of usage and environment.
- 

---

## **How to clean the soap outlet and how regularly (foam soap only)**

- + Remove the soap outlet with the hex key provided. Clean the filter on the soap outlet with a soft brush under water. It is recommended to clean the soap outlet every three months, depending on the soap used, frequency of usage and environment.
- 

---

## **What should NOT be used**

- + Do not use steel brush or abrasive that could scratch the spouts.
- 

---

## **Best care for PVD Finishes**

- + You can clean the PVD finished spouts with a damp cloth and water. Do not use cleaning solution or liquid alcohol.
-

# troubleshooting

---

## If the dispenser will not run

---

- + Ensure there is power to the dispenser and the wire from the fuse spur is connected correctly to the pump motor.
  - + Check that the sensor cables are fully connected to the corresponding cables from the foam pump unit.
  - + If you use DC type, replace the battery with a new one if the battery is low.
- 

---

## If the dispenser can be heard to operate, but soap is not dispensed

---

- + Check that the soap pick-up pipe is fully immersed in the soap in the reservoir. If necessary, replenish the soap in the reservoir and ensure it is pushed into the correct position in the mounting bracket.
  - + Check that there are no leaks in the pipework, and that all connections are fully pushed home.
- 

---

## If the dispenser runs all the time

---

- + It is likely that the sensor is detecting either an object, or reflection causing it to operate constantly.
  - + Remove the obstruction or cause of reflection.
- 

We are always looking to improve. If these did not solve your problem please contact us and we will endeavour to help.

Tel: +44 (0) 161 482 7000

Email: [Info.uk@thesplashlab.com](mailto:Info.uk@thesplashlab.com)

# diagram

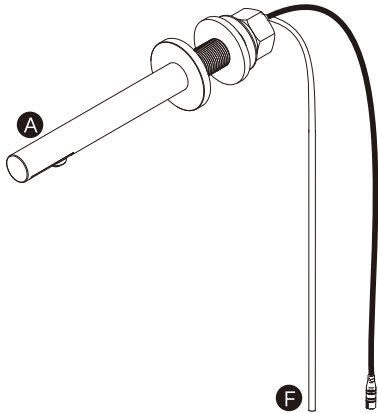

- A      Dispenser head assembly
- F      Soap foaming pipe - 1000mm
- G      Soap reservoir - 1500ml
- I      Soap foamer pump unit
- J      Power supply unit

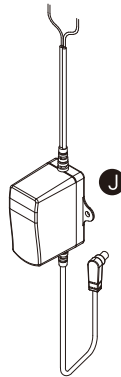
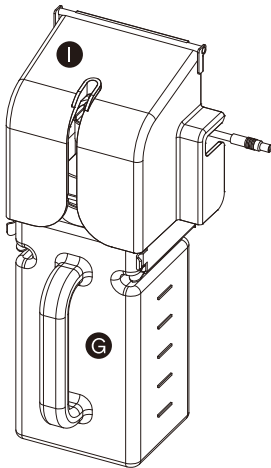



# warranty

**The Channel Soap Dispenser** will be warranted by The Splash Lab to be free of manufacturing and material defects during normal use and environmental conditions as detailed below:

One year limited warranty

- + If a defect is found in normal use, The Splash Lab will, at their discretion, repair, provide a replacement part or product, or make appropriate adjustments. Damage caused by accident, misuse, or abuse is not covered by this warranty. Improper care and cleaning will void the warranty.
- + Non-operation of the product due to environmental conditions beyond our control, installation error, incorrect maintenance, water quality, fair wear and tear, incorrect or inappropriate installation, misuse and abuse is not covered by the warranty.
- + Proof of purchase (original sales receipt) must be provided to The Splash Lab with all warranty claims.
- + The above warranty is valid for goods supplied within the U.K. & Europe.
- + For goods supplied outside of U.K. & Europe, The Splash Lab will honor the above stated warranty periods for the parts only.
- + THE SPLASH LAB DISCLAIM ANY LIABILITY FOR SPECIAL, INCIDENTAL OR CONSEQUENTIAL DAMAGES.





# contact



## General information

Info.uk@thesplashlab.com  
+44 (0) 161 482 7000

## Technical support

Info.uk@thesplashlab.com

**For further contact information visit:**

[www.thesplashlab.com](http://www.thesplashlab.com)

