

Compact WC Frame

490x500mm

Installation instructions

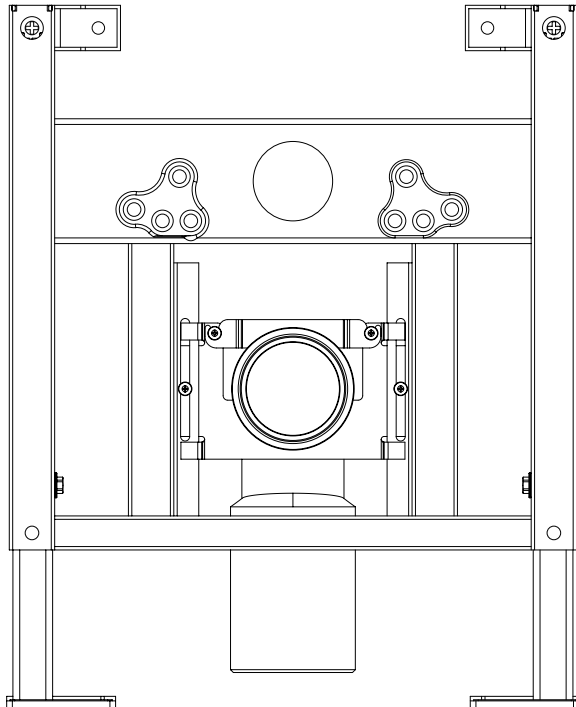

installation instructions

Parts supplied

A



1 x Wall Hung Support Frame

B



2 x Rubber Sound Deadening Pad for Feet

C



6 x M6 x 65mm Coach Bolt

D



6 x White Wall Plug 10mm

E



6 x M6 Washer

F



2 x M10 x 180mm Bolt

G



2 x M10 x 110mm Bolt

H



2 x M8 x 30mm Bolt

I



2 x M8 Washer

J



2 x Unistrut Fixing

K



2 x Wall Fixing Foot

L



2 x Bolt Location Block

M



2 x Bolt Retaining Clip

N



6 x M10 Push Fit Fastening Nut

O



2 x Pan Fixing Bolt

P



2 x Pan Fixing Nut

Q



1 x 90° Pan Connector

R



1 x Soil Pipe Extension & Rubber Cone

S



1 x Debris Stopper for Soil Pipe Extension

T



1 x Flush Pipe Extension & Corrugated Rubber Cone

U



1 x Debris Stopper for Flush Pipe Extension

V



1 x Greased Sponge

W



2 x Clear Pan Fixing Bolt Shroud

Y



2 x WC Pan Installation Bung

Z



2 x Chrome Cover Cap

Tools required (not supplied)

- + Tape Measure
- + Level
- + Pencil
- + Electric Drill
- + 10mm Drill Bit
- + Screwdriver PH3
- + PTFE Tape
- + Screwdriver PH2
- + Large Straight Blade Screwdriver
- + Spanner / Socket Set
- + Hacksaw
- + Retractable Blade Knife
- + Screwdriver PZ2

Important information

PLEASE READ THESE INSTRUCTIONS THOROUGHLY BEFORE STARTING INSTALLATION.

- + Check the pack and make sure you have all the parts listed.
- + Remove all cardboard protection attached to the frame prior to installation.
- + All floor types need to be as flat and level as possible.
- + When drilling or fixing into walls or floor it is essential that you check for pipes or wires before commencing.

Site Preparation

- + All floor types need to be clean, dry and dust free.
- + All floor types need to be as flat and level as possible.
- + Floor boards must be securely fixed down prior to installation.

Adjusting the frame

The frame feet can be adjusted to allow for uneven floors and finished floor build up. The frame allows for an additional 280mm adjustment on the standard height. Using a spanner or socket, loosen the bolts just above the feet and extend the feet to your desired height. Ensure that the frame is square using a level before tightening the bolts using a socket or spanner.

Before You Start

The first phase of installation is the securing of the frame to wall and floor. There are two methods of installation; either individual fixing or unistrut (rail) mounted fixing. The unistrut (rail) mounted system is normally used where multiple frames are to be mounted next to each other, i.e., a basin frame next to a WC frame or a row of frames. This is also the best option when fixing to stud walls rather than solid walls. Bypass step 2 if you plan to individually fix the frame.

Note: The rail kit is an optional extra and can be purchased from your merchant.

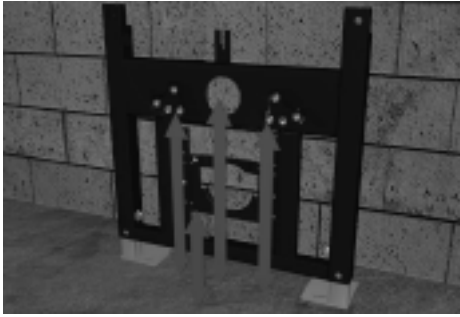

Step 1

Important! Set the frame to the WC manufacturer's recommendations for the soil & flush pipe and the fixing bolts location / spacing. The soil pipe height can be manually adjusted by loosening the two pan head screws on either side of the soil pipe internal frame. Ensure that the screws are re-tightened when the desired height is achieved. The pan bolts can be set at either 180mm or 230mm centres. The flush pipe height is fixed although can be raised or lowered by adjusting the frame feet accordingly. In addition the relationship between the bolt height and flush pipe height is also fixed.



Step 2

First ensure that the rail is the correct length for the frames to be mounted. If necessary, cut the rail to the required length (standard sizes available are 1.08m, 1.8m & 3.0m) using a hacksaw. Mark a horizontal line 80mm lower than the top of your frame using a pencil i.e., if the frame is the standard height of 820mm, you should mark your horizontal line at 740mm.

Using the pencil line as the centre point for the rail, secure it to the wall using the fixings supplied and ensure that it is mounted evenly using a level.

Note: For individual installation please omit this step.



Step 3

Fix the Rubber Sound Deadening Pads (B) to the WC Support Frame (A) feet. These help reduce noise transmission.

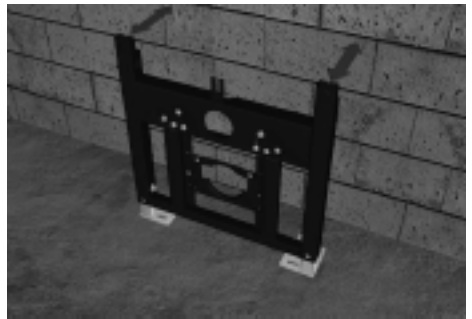

Step 4

Space the frame off the back wall to the required distance. The minimum installation depth is determined generally by the width of the frame leg plus the services running behind the frame. A tolerance of 120 - 265mm from wall to front face of the frame can be achieved with standard 'in the box' parts.

Note: An extension set is available which offers a further 160mm and can be purchased from your merchant .

Mark through using a pencil

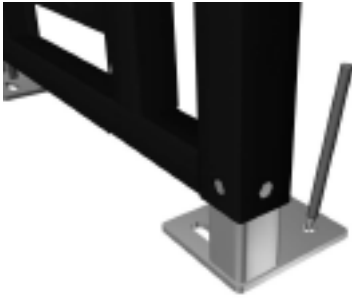

Solid floor application

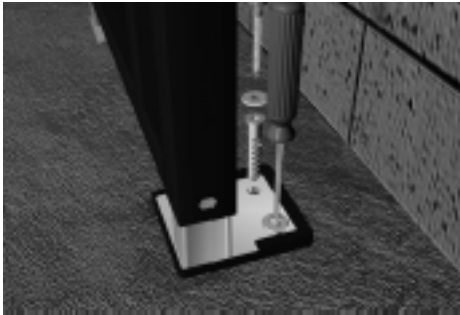

Timber floor application

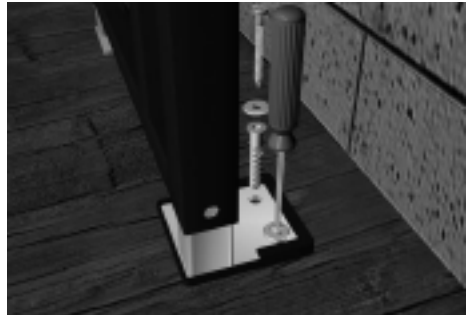

Step 5

Using a pencil, mark through the four holes in the Basin Frame (A) feet the fixing hole positions.

Timber floor application

Secure the feet into position by fixing the four M6 x 65mm Coach Bolts (C) and four M6 Washers (E) using a PH3 Screwdriver or Spanner and the pencil marks as a guide.

In the event of the Coach Bolts (C) being unsuitable for your particular application, please replace these items with your choice of comparable fixing.

Solid floor application

Drill four holes in the floor using a drill and 10mm drill bit using the pencil marks as a guide. Insert the four 10mm White Wall Plugs (D) into the holes. Secure the feet into position by fixing the four M6 x 65mm Coach Bolts (C) and four M6 Washers (E) using a PH3 Screwdriver or Spanner and the Wall Plug locations as a guide.

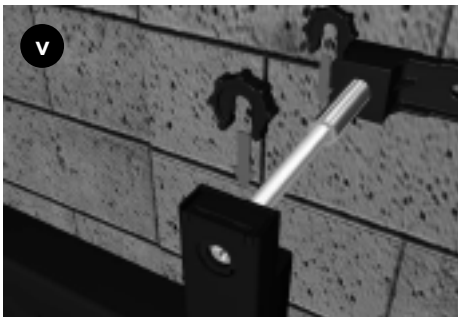
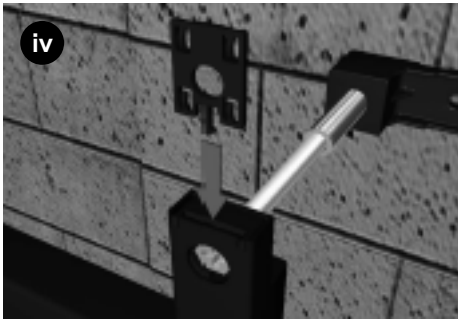
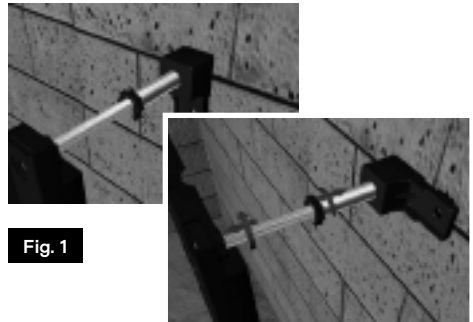
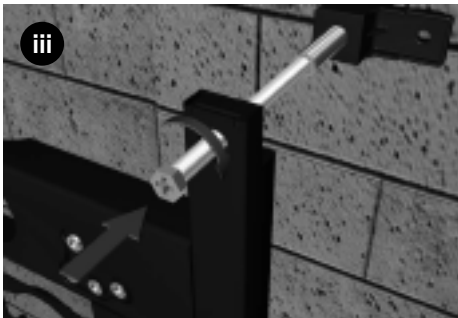
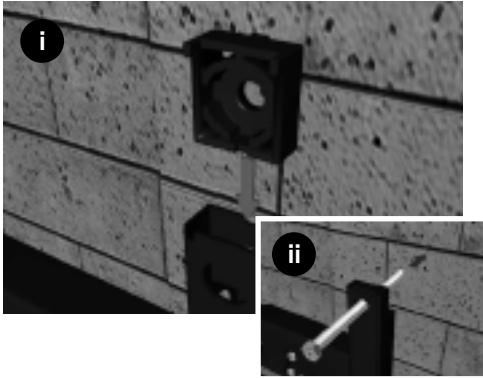

Fig. 1

Step 6

Place the two Bolt Location Blocks (L) into either side of the top frame profile. Dependant on the depth required and measured in Step 3, take either the two M10 x 180mm Bolts (F) for a tolerance of 120 - 200mm, or the two M10 x 110mm Bolts (G) for a tolerance of 190 - 265mm. Thread the two bolts (F) or (G) through the Bolt Location Blocks (L).

Fasten the two Wall Fixing Feet (K) to the bolts (F) or (G) to the desired depth measured in Step 3. The wall fixing feet can be fixed to the wall in a number of ways. Generally they should be installed with the screw hole pointing downwards for unistrut (rail), however where achievable they can be installed with the screw holes pointing outwards for ease of fixing. Insert the two Bolt Retaining Clips (M) into either side of the top frame profile with the raised face to the front. This captivates the bolts whilst still allows for tightening with a flat bladed screwdriver as needed. Fit two M10 Push Fit Fastening Nut (M) per bolt; the first at either end of the thread to lock the bolt into position.

Note: To achieve a minimum depth of 120mm you should only affix one M10 Push Fit Fastening Nut (M) per bolt and not two as instructed above.



Step 7

Using a pencil, mark through the two holes in the Wall Fixing Feet (K) the fixing hole positions.

Solid wall fixing

Drill two holes in the wall using a drill and 10mm drill bit using the pencil marks as a guide. Insert the two 10mm White Wall Plugs (D) into the holes. Secure the feet into position by fixing the two M6 x 65mm Coach Bolts (C) and two M6 Washers (E) using a PH3 Screwdriver and the Wall Plug locations as a guide.

Unistrut (Rail) Fixing

Insert the two unistrut fixings (J) into the unistrut (rail), then attach the Wall Fixing Feet (K) to the unistrut using one M8 x 30mm Bolt (H) and one M8 Washer (I) per Wall Fixing Foot (K).

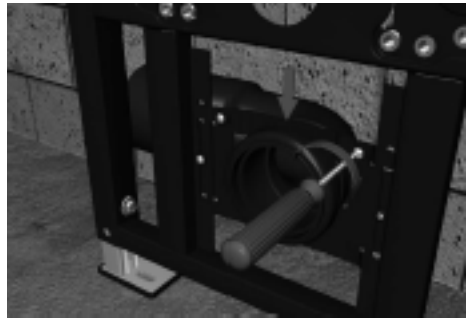
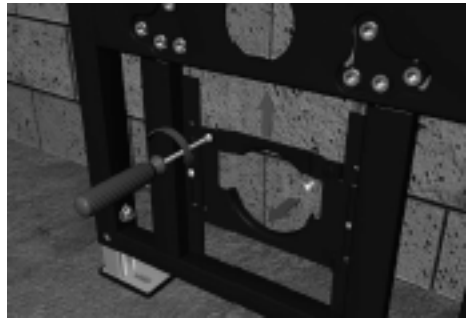
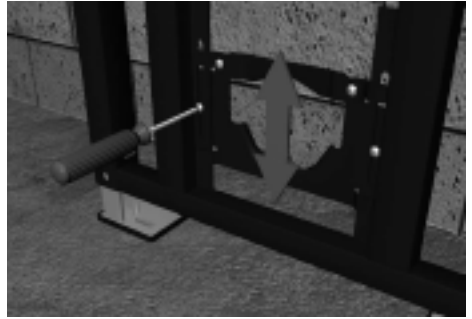

Step 8

To install the 90° Pan Connector (Q) within the cradle, slightly loosen one of the screws holding the top section of the cradle in place and remove the other screw temporarily and keep to one side. This should allow you to rotate the bracket high enough to install the 90° Pan Connector (Q). Clamp the top section back into place and replace and the screw removed earlier and tighten both securely. Connect the 90° Pan Connector (Q) to the soil pipe.

Note: The soil adapter is suitable for push fit 110mm pipe. A Straight Adapter is also available as an optional extra and can be purchased from your merchant.

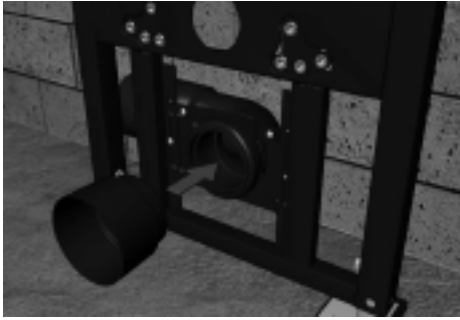

Step 9

Connect the Debris Stopper for Soil Pipe Extension (S) to the 90° Pan Connector (Q).

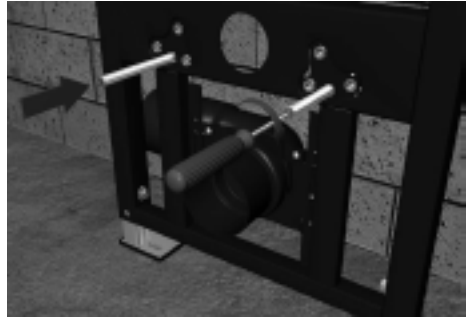

Step 10

Attach the two Pan Fixing Bolts (O). These can be wound down to the appropriate length as set out by the WC pan manufacturer using a straight bladed screwdriver.

Install your choice of concealed cistern and install either timber or metal studwork either side of the frame/ before then plaster boarding and tiling.

Connect the Debris Stopper for Flush Pipe Extension (U).

Note: The frame comes with holes in either leg; these can be used to fix a screw into the studwork at either side for added strength as required.

*** The frame is now ready for 2nd Fix Installation ***



Step 11

Discard the Debris Stopper for Soil Pipe Extension (S) and Debris Stopper for Flush Pipe Extension (U). Apply grease liberally around the Cistern Flush Pipe and 90° Pan Connector (Q) using the Greased Sponge (V).

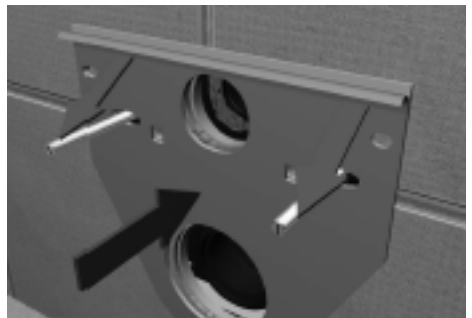

Step 12 (optional)

Only applicable if you have purchased the Anti-noise Fixing Pad.

Remove the backing paper from the Self Adhesive Fixing Pad and apply to the tile face in the proposed WC location with the adhesive face forward (so it will stick to the rear of the WC Pan). This will help with sound dampening and provide a cushion between the sanitaryware and the tiled wall.



Step 13 (shown with optional Anti-noise Fixing Pad)

Cut down the Flush Pipe Extension & Corrugated Rubber Cone (T) and Soil Pipe Extension & Rubber Cone (R) according to the WC pan being installed. If the two Pan Fixing Bolts (O) need any further adjustment at this stage they can be wound down to the desired length using a straight bladed screwdriver. Place the two Clear Pan Fixing Bolt Shrouds (W) over the two Pan Fixing Bolts (O) and cut to suit the length of the bolts but also to allow for the two Pan Fixing Nuts (P).



Step 14

Install the WC Pan (not supplied) and fix to the wall using the two WC Pan Installation Bungs (Y) and two Pan Fixing Nuts (P). Place the two Chrome Cover Caps (Z) over the two WC Pan Installation Bungs (Y) and carefully remove any excess visible foam from the Anti-Noise Fixing Pad if fitted.



**For any further information
please contact your merchant**

The manufacturer reserves the right to make technical modifications without prior notice.