

# Wall Mounted Sensor Operated Soap Dispenser

TSL.937

Wall Mounted Sensor Operated Soap Dispenser - Battery Operated

Finish	Codes	LRV*
● Black	TSL.937.BK	3
● Brass	TSL.937.BR	40
● Satin	TSL.937.CS	58
● Bronze	TSL.937.BZ	17
● Copper	TSL.937.CP	19

Light Reflectance Value\*

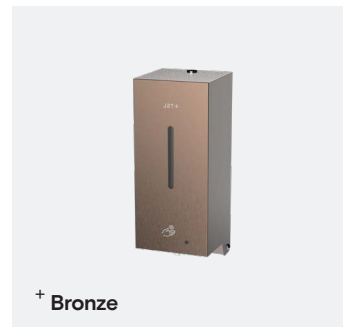
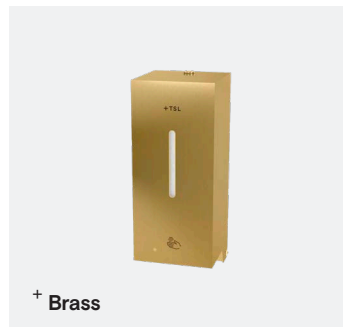

## Technical Data

Weight	1.4kg
Recommended soap viscosity	Liquid soap:1-3000cPs Foam soap - <10cPs. Not suitable for alcohol gels or hand sanitisers.
Stainless steel grade	304 Stainless steel
Sensor range preset	75±15mm (Not adjustable)
Power supply - Battery	6V Type AA x 4 pcs Alkaline (not included) (Optional)
Pump Life Estimated	25,000 cycles
Standby power	0.3mA
Warranty	One Year Parts and Unlimited Online Support

## Installation requirements

Reflective surfaces	Not to be installed above highly polished surfaces
Soap foam requirements	To utilise the TSL.AFS Aromatherapy Foam Soap the additional purchase of the TSL.P260056 Foam Pump is required.

## Included

Wall Mounted Sensor Operated  
Soap Dispenser

Dispenser cover

Screws

Baseplate

Soap tank cap

Soap tank -800ml

Valve (liquid, foam)

Control box

## + Technical drawing

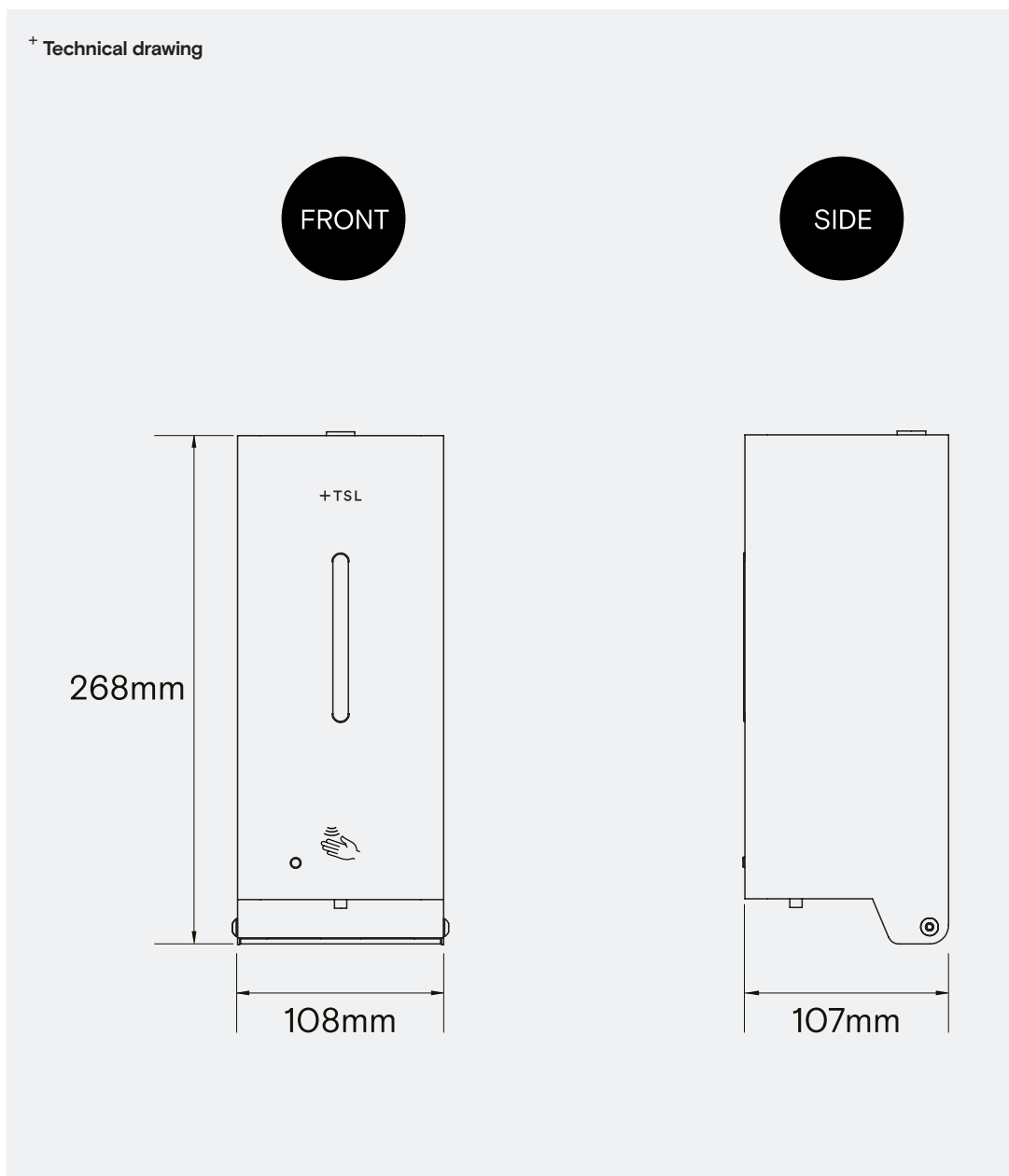

## Warranty & Spare parts

For warranty terms and conditions please visit [www.thesplashlab.com](http://www.thesplashlab.com)

If additional spare parts are required and are not listed above, please contact us at [info.uk@thesplashlab.com](mailto:info.uk@thesplashlab.com)

Part	Codes
Liquid Nozzle	TSLP.260055
Control box	TSLP.260057

## Related products

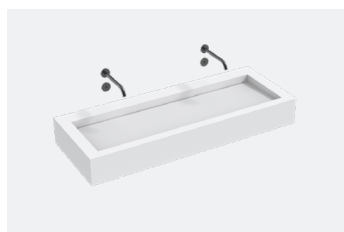

**The Monolith M Series**  
TSL.M

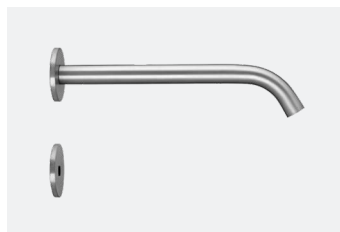

**150mm IR Sensor Tap**  
TSL.884