

IR Sensor Tap

TSL.882

The TSL.882 features a sleek wall mounted spout with accompanying sensor housing and is available in a range of finishes.

Finish	Codes	LRV*
● Satin	TSL.882.CS	58
● Black	TSL.882.BK	3
● Brass	TSL.882.BR	40
● Copper	TSL.882.CP	19
● Chrome	TSL.882.C	75

Light Reflectance Value*

+ Satin



+ Black



+ Brass

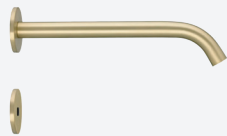

+ Chrome

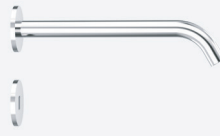

+ Copper

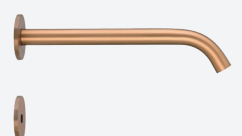

Technical Data

Body Material	AISI 304 Stainless Steel
Coating Type	PVD (colours only)
Aerator	Cascade
Water Pressure (Dynamic)	0.5 to 7.5 Bar [0.05 to 0.75MPa]
Water Temperature (max)	60°C
Flow Rates	3.8 litres/minute - Cascade flow 1.9 litres / minute - Spray flow
Also available	1.3 litres / minute - Spray flow
Power supply	TSL-882 110-230 Vac, 50-60Hz, 1.5A, 6 V CR-P2 Lithium battery
Output (max)	6 Vdc, 1A
Power consumption	< 87% Active mode, 0.3W No load
Solenoid valve type	6V Latching
Water Ingress	IP55
Cable lengths	800mm - Power supply connection 800mm - Solenoid valve connection
Sensor type	Infrared
Pre-set sensor range	220mm
Sensor range (max)	250mm
Comfort delay	2 sec
Security time-out	30 sec
Operating Temperature	0 to 50°C
Response Time (max)	0.3 - < 1 sec

Installation requirements

Wall Cut-out Hole Size	Ø16mm (Spigot) Ø40mm (Sensor Housing)
Depth of Wall Cavity (min)	90mm
Wall Thickness (max)	50mm (incl. finishes)
Plumbing Connection	½" BSP (female) brass fitting is required to connect to the solenoid valve housing
Power supply cable	To be hard wired in to fused connection unit (FCU) or spur
Water supply	1.0 Bar is the recommended minimum pressure for the taps to operate effectively. 7.5 Bar is the maximum pressure for commissioning and is NOT recommended for general use Gravity-fed systems may require a booster pump to achieve the optimal operating pressure All pipework must be thoroughly cleaned and clear of any debris before connecting the tap
Washroom layout	Solenoid valve must be accessible for installation, commissioning and ongoing maintenance. Avoid installing the sensor tap directly opposite other sensor taps, soap dispensers, infrared devices or reflective surfaces. Careful consideration should be made when choosing the positioning of lighting and other reflective surfaces which may affect sensor performance

Compliance & certificates

BREEAM, LEED	
EMC compliance	Electromagnetic compatibility directive 2004/108/CE, and Low Voltage 2006/95/CR
WRAS	Certificate No 1809302

+ Installed view

IDE
FRONT

SIDE

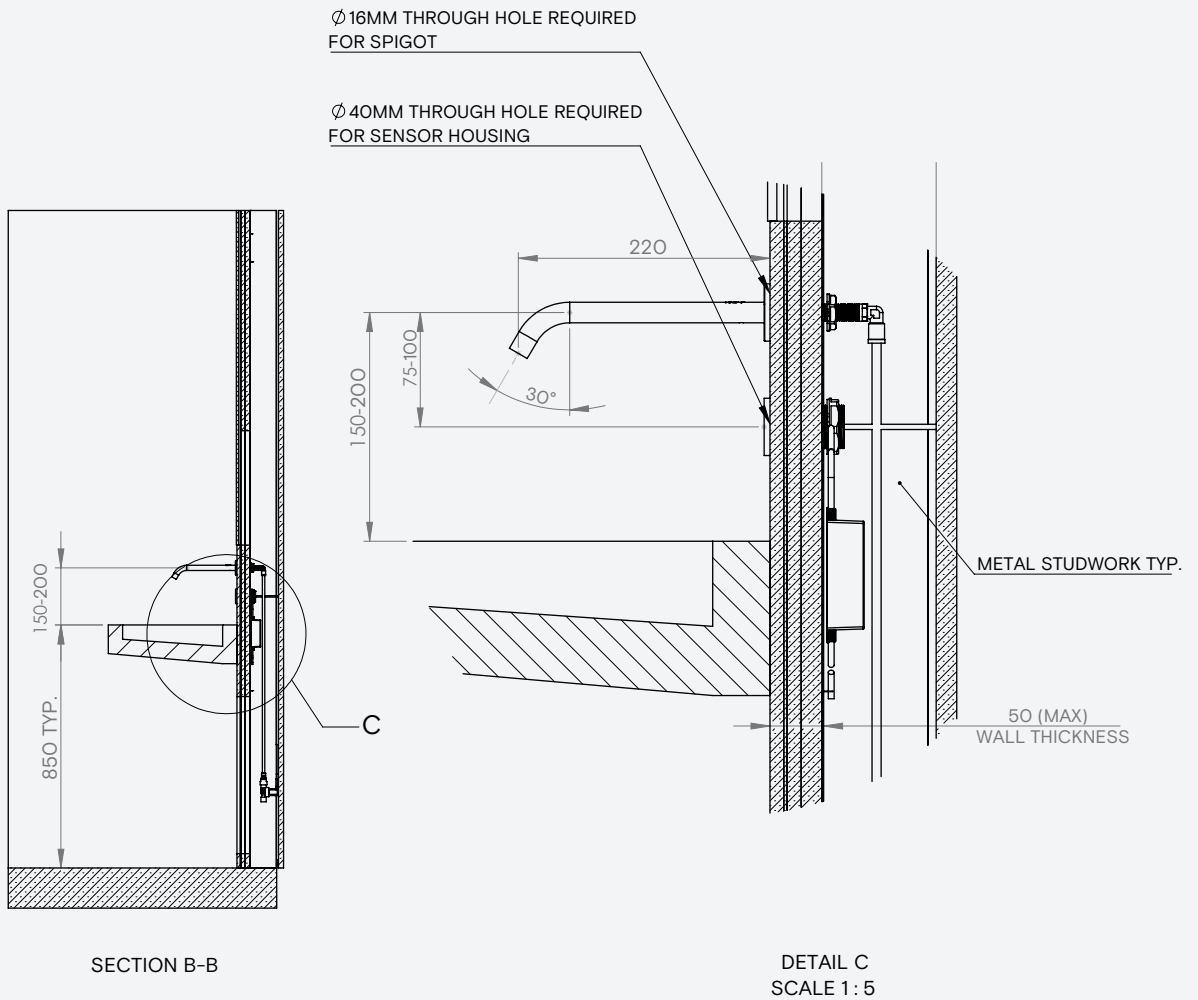

Technical drawings continued on following page

+ **Access requirements**

OPTION A:
TAP TO BE SERVICEABLE FROM
BEHIND THE MIRROR (NOT SHOWN)

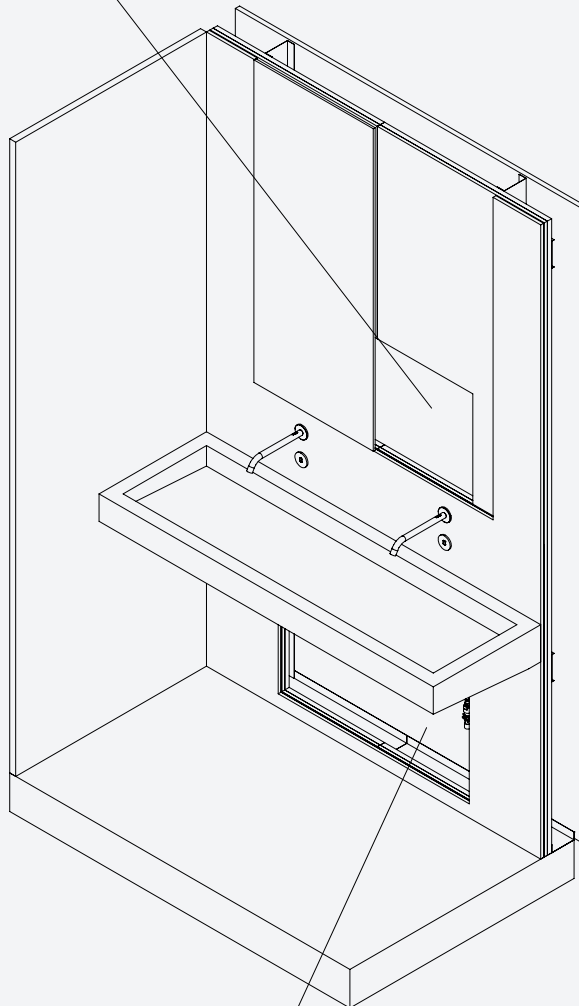

OPTION B:
TAP TO BE SERVICEABLE VIA ACCESS HATCH OR PANEL

Technical drawings continued on following page

Key Components/Spare Parts

Solenoid Connector Cable
TSLP.120032

Mains Power Supply 6V
TSLP.270066

Long Range IR Sensor
TSLP.260045

Solenoid Valve
TSLP.120030

Aerator Key
TSLP.260050

Aerator Cascade 3.8L/min Airated
TSLP.260062

Aerator Cascade 1.89L/min Spray
TSLP.260063

Basket Filter for Solenoid Valve
TSLP.08530015

Optional Extras

Lithium Battery 6V
TSLP.270030

Battery Holder
TSLP.270029

Aerator Cascade 1.35L/min Spray
TSLP.260051

+ Technical drawing

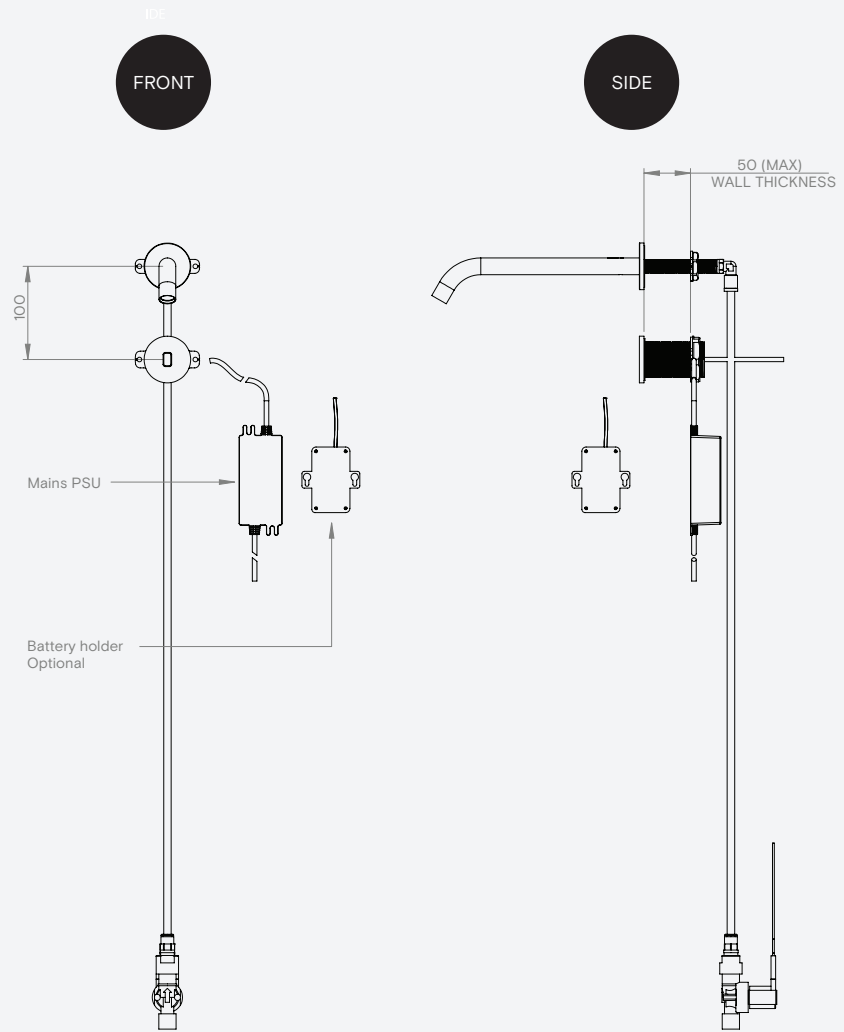

Warranty & Spare parts

For warranty terms and conditions please visit www.thesplashlab.com

If additional spare parts are required and are not listed above, please contact us at info.uk@thesplashlab.com

Related products



Wall Mounted Sensor Soap Dispenser
TSL.467

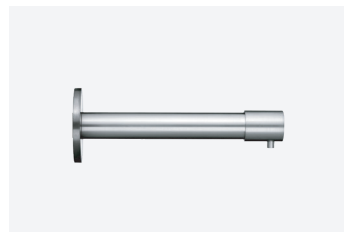

Wall Mounted Manual Soap Dispenser
TSL.470



150mm IR Sensor Tap
TSL.884



Monolith M Series - 450mm
TSL.M